

▶ MM2 Series (Ø20~Ø40)

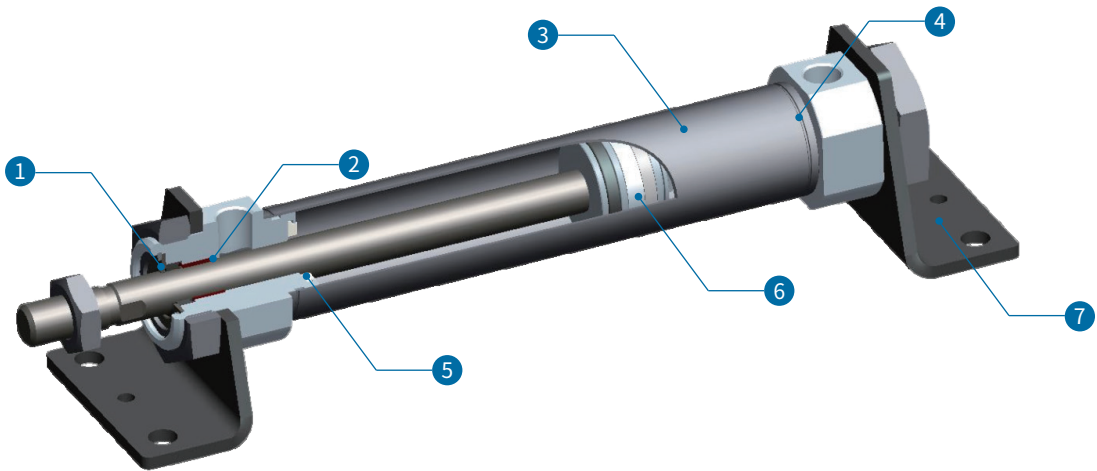

1

Rod seal with wiper for operation in dusty environments

2

Front cover with built-in guide bushing reduces clearance between piston rod and cylinder, improving alignment accuracy

3

Cylinder tube made of corrosion-resistant stainless steel pipe

4

Built-in magnet for mounting magnetic switches

5

Various cushioning structures suitable for high-speed driving

6

Built-in wear-resistant ring to effectively extend service life

7

Various mounting methods, easy to install with high mounting accuracy

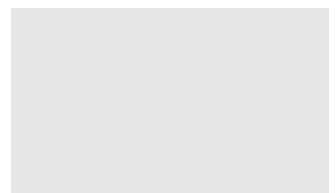

Standard Cylinders

MM2 Series



Standard Specifications

| | | | | | |
|--------------------------|--|-------|------|-------|------|
| Bore (mm) | 20 | 25 | 32 | 40 | |
| Operating Medium | Air | | | | |
| Operation Type | Double-acting | | | | |
| Max. Operating Pressure | 1.0MPa | | | | |
| Min. Operating Pressure | Single-rod double-acting: 0.05MPa, Double-rod double-acting: 0.08MPa | | | | |
| Proof Pressure | 1.5MPa | | | | |
| Ambient/Medium Temp. | Without Mag. Switch: -10°C~70°C, With Mag. Switch: -10°C~60°C | | | | |
| Piston Speed | With Cushion: 50~750mm/s Without Cushion: 50~1000mm/s | | | | |
| Cushion | Rubber Cushion / No Cushion | | | | |
| Lubrication | Not Required | | | | |
| Stroke Tolerance | +1.40mm | | | | |
| Allowable Kinetic Energy | External thread | 0.27J | 0.4J | 0.65J | 1.2J |
| Port Size | Rc1/8 | G1/8 | G1/8 | G1/4 | |

Symbols

| | |
|--------------------------|--|
| Single-rod double-acting | |
| Double-rod double-acting | |

Product Features

- Cylinder tube made of stainless steel pipe
- Front and rear covers integrally bound with cylinder tube, impact resistant, high strength
- Rod seal with wiper, suitable for dusty environments
- Front cover designed with replaceable rod seal to extend service life
- Front cover with built-in guide bushing reduces clearance, improving alignment accuracy
- Various cushioning options for high-speed driving
- Various mounting methods, easy to install with high mounting accuracy

Cylinder Theoretical Output Force Table

Unit: N

| Bore (mm) | Piston Rod Dia (mm) | Operation Type | Effective Area (mm ²) | Air Pressure (MPa) | | | | | | | |
|-----------|---------------------|----------------|-----------------------------------|--------------------|-------|-------|-------|-------|-------|-------|-------|
| | | | | 0.1 | 0.2 | 0.3 | 0.4 | 0.5 | 0.6 | 0.7 | |
| 20 | 8 | Double-acting | Extend | 314 | 31.4 | 62.8 | 94.2 | 125.6 | 157 | 188.4 | 219.8 |
| | | | Retract | 263.8 | 26.4 | 52.8 | 79.1 | 105.5 | 131.9 | 158.3 | 184.6 |
| 25 | 10 | Double-acting | Extend | 490.6 | 49.1 | 98.1 | 147.2 | 196.3 | 245.3 | 294.4 | 343.4 |
| | | | Retract | 412.1 | 41.2 | 82.4 | 123.6 | 164.9 | 206.1 | 247.3 | 288.5 |
| 32 | 12 | Double-acting | Extend | 803.8 | 80.4 | 160.8 | 241.2 | 321.5 | 401.9 | 482.3 | 562.7 |
| | | | Retract | 690.8 | 69.1 | 138.2 | 207.2 | 276.3 | 345.4 | 414.5 | 483.6 |
| 40 | 14 | Double-acting | Extend | 1256 | 125.6 | 251.2 | 376.8 | 502.4 | 628 | 753.6 | 879.2 |
| | | | Retract | 1102.2 | 110.3 | 220.5 | 330.7 | 440.9 | 551.1 | 661.4 | 771.6 |

Model Selection

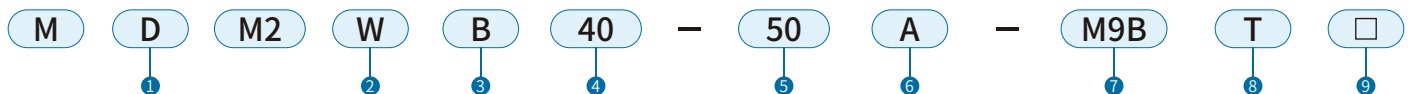

| 1 Built-in magnetic ring | | 2 Piston Rod | | 3 Mounting Type | | 4 Bore | | 5 Stroke | | 6 Bore | | 7 Mounting Type | | 8 Cable carrier | | 9 Number of Switches | |
|--------------------------|-------------------------|--------------|--------|-----------------|---|--------|-------|----------------------|---------|--------------------------|---------|--------------------|-------|----------------------------------|---------|--------------------------|---|
| No Mark | No Magnet | No Mark | Single | B | Basic Type | 20 | ∅20mm | Refer to Stroke List | No Mark | Rubber Cushion | No Mark | No Magnetic Switch | Blank | Standard (Not for cable carrier) | No Mark | 2个 | |
| D | With Magnet | W | Double | BZ | boss-cut basic style (single rod double acting) | 25 | ∅25mm | | | | A | Air cushion | | | M9B | 2-wire Electronic Switch | T |
| | | | | L | Axial foot style | 32 | ∅32mm | | M9N | 3-wire Electronic Switch | | | N | N个 | | | |
| | | | | F | Rod side flange style | 40 | ∅40mm | | | | | | | | | | |
| G | Head flange style | | | | | | | | | | | | | | | | |
| E | Integrated clevis style | | | | | | | | | | | | | | | | |

[Note] Standard cable length 2m. For models with 1m, 3m, 5m cable lengths, please refer to the magnetic switch series catalog

Standard Cylinders

MM2 Series

Magnetic Switch Table

| Bore (mm) | Standard Stroke | Max. Stroke (mm) | | Magnetic Switch Table | |
|-----------|----------------------------------|--------------------------|--------------------------|-----------------------|------------------------|
| | | Single-rod double-acting | Double-rod double-acting | Magnetic Switch Model | Mounting Bracket Model |
| 20 | 25,50,75,100,125,150,200,250,300 | 1000 | 300 | SW-M9B SW-M9N | SK-B-20 |
| 25 | | | | | SK-B-25 |
| 32 | | | | | SK-B-32 |
| 40 | | | | | SK-B-40 |

[Note 1] Any stroke in 1mm increments can be manufactured.

[Note 2] For strokes exceeding 30mm, refer to cylinder stroke selection data to determine the maximum usable stroke.

订货举例

| | | |
|---------------------------------|-----------------|---|
| Complete Cylinder Order Example | MDM2B20-50A-M9B | Cylinder with magnet, air cushion, bore 20, stroke 50, with magnetic switch |
| Magnetic Switch | SW-M9B | 2m cable length Unit/pc |
| Magnetic Switch Bracket | SK-B-20 | This model is the bracket for 20 bore |

Standard Cylinders

MM2 Series

Outline Dimension Drawings (mm)

► Single-rod double-acting Basic Type (B)

► M□M2B Bore-Stroke □

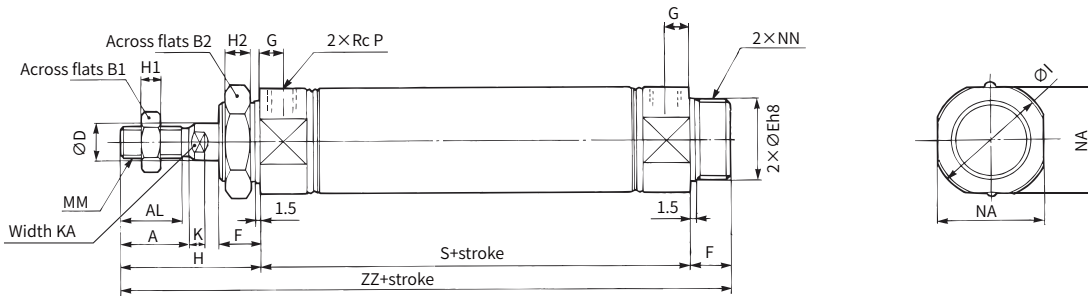

► Adjustable cushion

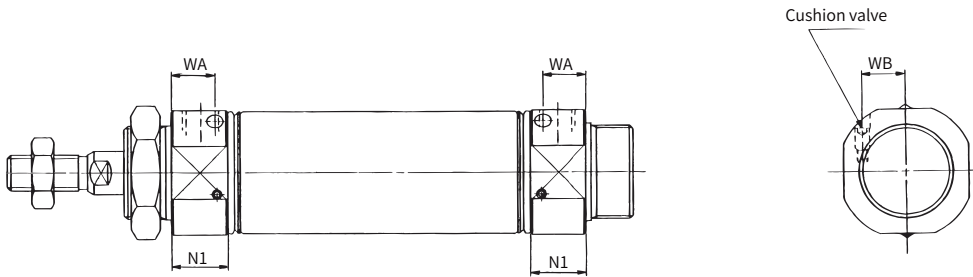

► Fixed cushion

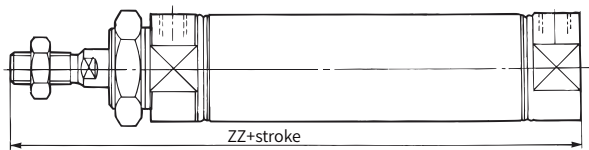

| Bore | A | AL | B1 | B2 | D | E | F | G | H | H1 | H2 | I | K | KA | MM | NA | NN | P | S | ZZ |
|------|----|------|----|----|----|----------------------------------|----|----|----|----|----|------|-----|----|----------|------|---------|-----|----|-----|
| 20 | 18 | 15.5 | 13 | 26 | 8 | 20 ⁰ _{0.033} | 13 | 8 | 41 | 5 | 8 | 28 | 5 | 7 | M8×1.25 | 24 | M20×1.5 | 1/8 | 62 | 116 |
| 25 | 22 | 19.5 | 17 | 32 | 10 | 26 ⁰ _{0.033} | 13 | 8 | 45 | 6 | 8 | 33.5 | 5.5 | 8 | M10×1.25 | 30 | M26×1.5 | 1/8 | 62 | 120 |
| 32 | 22 | 19.5 | 17 | 32 | 12 | 26 ⁰ _{0.033} | 13 | 8 | 45 | 6 | 8 | 37.5 | 5.5 | 10 | M10×1.25 | 34.5 | M26×1.5 | 1/8 | 64 | 122 |
| 40 | 24 | 21 | 22 | 41 | 14 | 32 ⁰ _{0.039} | 16 | 11 | 50 | 8 | 10 | 46.5 | 7 | 12 | M14×1.5 | 42.5 | M32×2 | 1/4 | 88 | 154 |

► Fixed cushion

| Bore | ZZ |
|------|-----|
| 20 | 103 |
| 25 | 107 |
| 32 | 109 |
| 40 | 138 |

► Adjustable cushion

| Bore | N1 | WA | WB |
|------|------|----|------|
| 20 | 17.5 | 13 | 8.5 |
| 25 | 17 | 13 | 10.3 |
| 32 | 17.5 | 13 | 11.5 |
| 40 | 21.5 | 16 | 15 |

► Mounting Type / Mounting Model

| Bore mm | 20 | 25 | 32 | 40 |
|------------|----------|----------|----------|----------|
| Axial base | MM2-L020 | MM2-L032 | MM2-L032 | MM2-L040 |
| Flange | MM2-F020 | MM2-F032 | MM2-F032 | MM2-F040 |

Standard Cylinders MM2 Series

Outline Dimension Drawings (mm)

- ▶ Axial foot style (L)
- ▶ M□M2L Bore-Stroke □

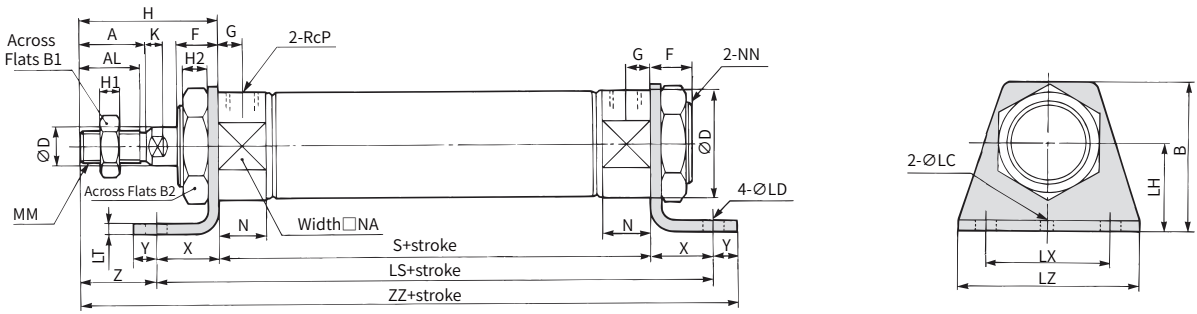

- ▶ Adjustable cushion

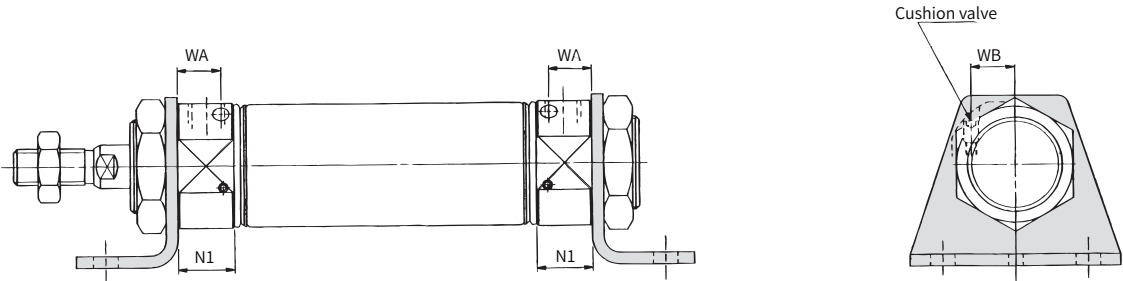

| Bore | A | AL | B | B1 | B2 | D | F | G | H | H1 | H2 | I | K | LC | LD | LH | LS | LT | LX | LZ | MM | N | NA | NN | P | S | X | Y | Z | ZZ |
|------|----|------|----|----|----|----|----|----|----|----|----|------|-----|----|-----|----|-----|----|----|----|----------|------|------|---------|-----|----|----|----|----|-----|
| 20 | 18 | 15.5 | 40 | 13 | 26 | 8 | 13 | 8 | 41 | 5 | 8 | 28 | 5 | 4 | 6.8 | 25 | 102 | 3 | 40 | 55 | M8×1.25 | 15 | 24 | M20×1.5 | 1/8 | 62 | 20 | 8 | 21 | 131 |
| 25 | 22 | 19.5 | 47 | 17 | 32 | 10 | 13 | 8 | 45 | 6 | 8 | 33.5 | 5.5 | 4 | 6.8 | 28 | 102 | 3 | 40 | 55 | M10×1.25 | 15 | 30 | M26×1.5 | 1/8 | 62 | 20 | 8 | 25 | 135 |
| 32 | 22 | 19.5 | 47 | 17 | 32 | 12 | 13 | 8 | 45 | 6 | 8 | 37.5 | 5.5 | 4 | 6.8 | 28 | 104 | 3 | 40 | 55 | M10×1.25 | 15 | 34.5 | M26×1.5 | 1/8 | 64 | 20 | 8 | 25 | 137 |
| 40 | 24 | 21 | 54 | 22 | 41 | 14 | 16 | 50 | 50 | 8 | 10 | 46.5 | 7 | 4 | 7 | 30 | 134 | 3 | 55 | 75 | M14×1.5 | 21.5 | 42.5 | M32×2 | 1/4 | 88 | 23 | 10 | 27 | 171 |

- ▶ Adjustable cushion

| Bore | N1 | WA | WB |
|------|------|----|------|
| 20 | 17.5 | 13 | 8.5 |
| 25 | 17 | 13 | 10.3 |
| 32 | 17.5 | 13 | 11.5 |
| 40 | 21.5 | 16 | 15 |

Standard Cylinders

MM2 Series

Outline Dimension Drawings (mm)

► Rod side flange style (F)

► M□M2F Bore-Stroke □

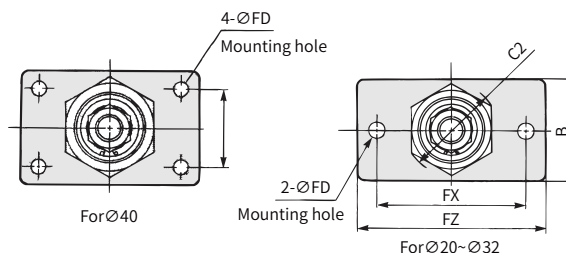
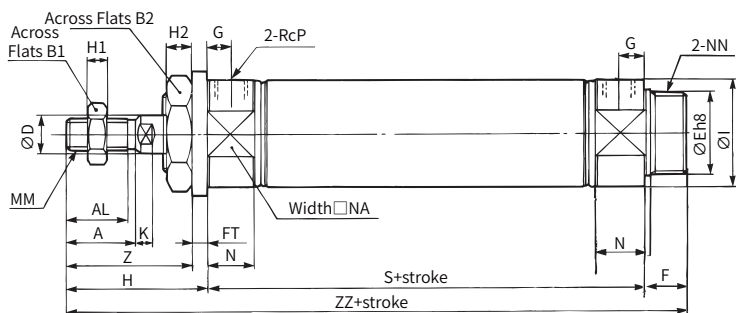

► Fixed cushion

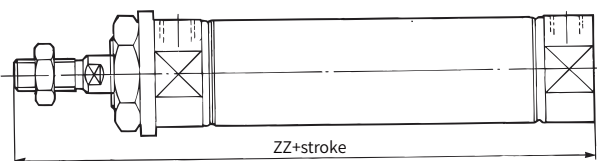

► Adjustable cushion

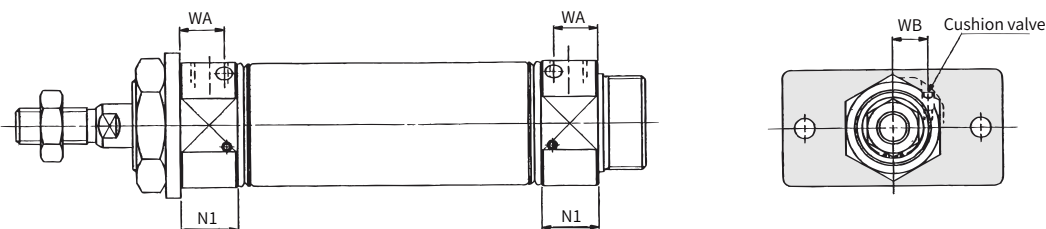

| Bore | A | AL | B | B1 | B2 | C2 | D | E | F | FD | FT | FX | FY | FZ | G | H | H1 | H2 | I | K | MM | N | NA | NN | P | S | Z | ZZ |
|------|----|------|----|----|----|------|----|----------------------------------|----|----|----|----|----|----|----|----|----|----|------|-----|----------|------|------|---------|-----|----|----|-----|
| 20 | 18 | 15.5 | 34 | 13 | 26 | 30 | 8 | 20 ⁰ _{0.033} | 13 | 7 | 4 | 60 | - | 75 | 8 | 41 | 5 | 8 | 28 | 5 | M8×1.25 | 15 | 24 | M20×1.5 | 1/8 | 62 | 37 | 116 |
| 25 | 22 | 19.5 | 40 | 17 | 32 | 37 | 10 | 26 ⁰ _{0.033} | 13 | 7 | 4 | 60 | - | 75 | 8 | 45 | 6 | 8 | 33.5 | 5.5 | M10×1.25 | 15 | 30 | M26×1.5 | 1/8 | 62 | 41 | 120 |
| 32 | 22 | 19.5 | 40 | 17 | 32 | 37 | 12 | 26 ⁰ _{0.033} | 13 | 7 | 4 | 60 | - | 75 | 8 | 45 | 6 | 8 | 37.5 | 5.5 | M10×1.25 | 15 | 34.5 | M26×1.5 | 1/8 | 64 | 41 | 122 |
| 40 | 24 | 21 | 52 | 22 | 41 | 47.3 | 14 | 32 ⁰ _{0.039} | 16 | 7 | 5 | 66 | 36 | 82 | 11 | 50 | 8 | 10 | 46.5 | 7 | M14×1.5 | 21.5 | 42.5 | M32×2 | 1/4 | 88 | 45 | 154 |

► Fixed cushion

| Bore | ZZ |
|------|-----|
| 20 | 103 |
| 25 | 107 |
| 32 | 109 |
| 40 | 138 |

► Adjustable cushion

| Bore | N1 | WA | WB |
|------|------|----|------|
| 20 | 17.5 | 13 | 8.5 |
| 25 | 17 | 13 | 10.3 |
| 32 | 17.5 | 13 | 11.5 |
| 40 | 21.5 | 16 | 15 |

Standard Cylinders

MM2 Series

Outline Dimension Drawings (mm)

► Head flange style (G)

► M□M2G Bore-Stroke □

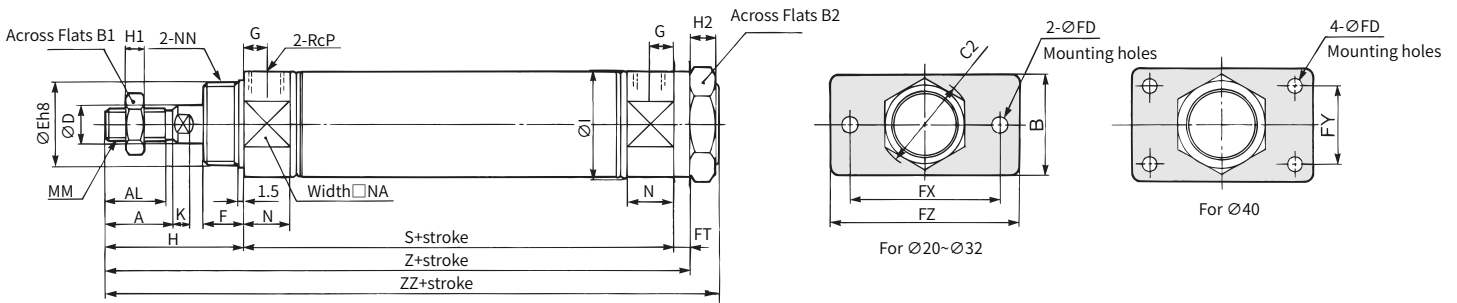

► Adjustable cushion

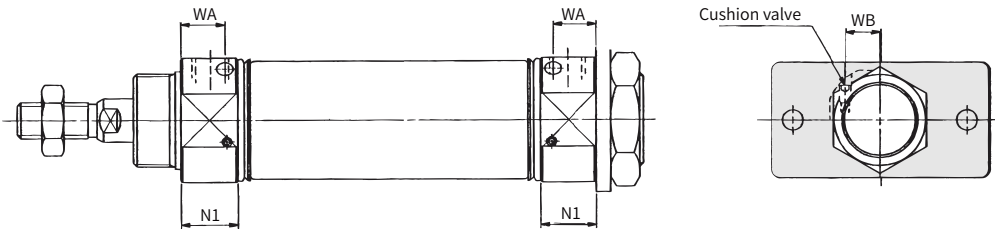

| Bore | A | AL | B | B1 | B2 | C2 | D | E | F | FD | FT | FX | FY | FZ | G | H | H1 | H2 | I | K | MM | N | NA | NN | P | S | Z | ZZ |
|------|----|------|----|----|----|------|----|----------------------------------|----|----|----|----|----|----|----|----|----|----|------|-----|----------|------|------|---------|-----|----|-----|-----|
| 20 | 18 | 15.5 | 34 | 13 | 26 | 30 | 8 | 20 ⁰ _{0.033} | 13 | 7 | 4 | 60 | - | 75 | 8 | 41 | 5 | 8 | 28 | 5 | M8×1.25 | 15 | 24 | M20×1.5 | 1/8 | 62 | 107 | 116 |
| 25 | 22 | 19.5 | 40 | 17 | 32 | 37 | 10 | 26 ⁰ _{0.033} | 13 | 7 | 4 | 60 | - | 75 | 8 | 45 | 6 | 8 | 33.5 | 5.5 | M10×1.25 | 15 | 30 | M26×1.5 | 1/8 | 62 | 111 | 120 |
| 32 | 22 | 19.5 | 40 | 17 | 32 | 37 | 12 | 26 ⁰ _{0.033} | 13 | 7 | 4 | 60 | - | 75 | 8 | 45 | 6 | 8 | 37.5 | 5.5 | M10×1.25 | 15 | 34.5 | M26×1.5 | 1/8 | 64 | 113 | 122 |
| 40 | 24 | 21 | 52 | 22 | 41 | 47.3 | 14 | 32 ⁰ _{0.039} | 16 | 7 | 5 | 66 | 36 | 82 | 11 | 50 | 8 | 10 | 46.5 | 7 | M14×1.5 | 21.5 | 42.5 | M32×2 | 1/4 | 88 | 143 | 154 |

► Adjustable cushion

| Bore | N1 | WA | WB |
|------|------|----|------|
| 20 | 17.5 | 13 | 8.5 |
| 25 | 17 | 13 | 10.3 |
| 32 | 17.5 | 13 | 11.5 |
| 40 | 21.5 | 16 | 15 |

Standard Cylinders

MM2 Series

Outline Dimension Drawings (mm)

► Integrated clevis style (E)

► M□M2E Bore-Stroke □

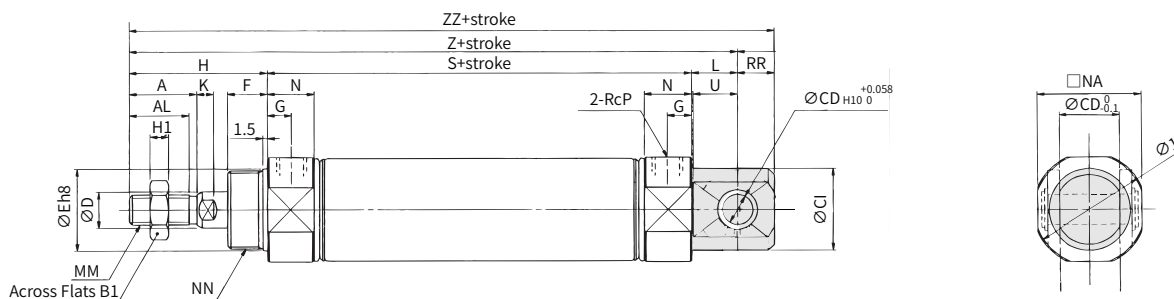

► Adjustable cushion

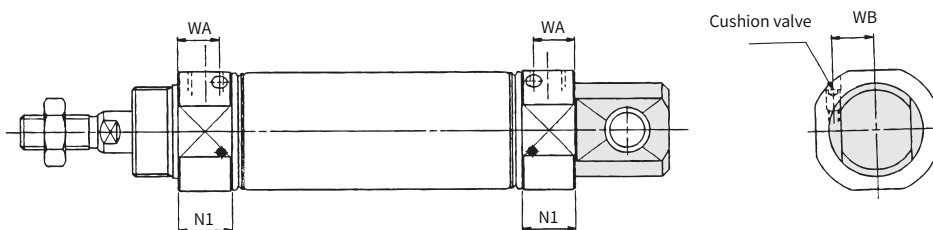

| Bore | A | AL | B1 | CD | CI | CX | D | E | F | G | H | H1 | I | K | L | MM | N | NA | NN | P | RP | S | U | Z | ZZ |
|------|----|------|----|----|----|----|----|----------------------------------|----|----|----|----|------|-----|----|----------|------|------|---------|-----|----|----|------|-----|-----|
| 20 | 18 | 15.5 | 13 | 8 | 20 | 12 | 8 | 20 ⁰ _{0.033} | 13 | 8 | 41 | 5 | 28 | 5 | 12 | M8×1.25 | 15 | 24 | M20×1.5 | 1/8 | 9 | 62 | 11.5 | 115 | 124 |
| 25 | 22 | 19.5 | 17 | 8 | 22 | 12 | 10 | 26 ⁰ _{0.033} | 13 | 8 | 45 | 6 | 33.5 | 5.5 | 12 | M10×1.25 | 15 | 30 | M26×1.5 | 1/8 | 9 | 62 | 11.5 | 119 | 128 |
| 32 | 22 | 19.5 | 17 | 10 | 27 | 20 | 12 | 26 ⁰ _{0.033} | 13 | 8 | 45 | 6 | 37.5 | 5.5 | 15 | M10×1.25 | 15 | 34.5 | M26×1.5 | 1/8 | 12 | 64 | 14.5 | 124 | 136 |
| 40 | 24 | 21 | 22 | 10 | 33 | 20 | 14 | 32 ⁰ _{0.039} | 16 | 11 | 50 | 8 | 46.5 | 7 | 15 | M14×1.5 | 21.5 | 42.5 | M32×2 | 1/4 | 12 | 88 | 14.5 | 153 | 165 |

► Adjustable cushion

| Bore | N1 | WA | WB |
|------|------|----|------|
| 20 | 17.5 | 13 | 8.5 |
| 25 | 17 | 13 | 10.3 |
| 32 | 17.5 | 13 | 11.5 |
| 40 | 21.5 | 16 | 15 |

Ordering Examples

| | | |
|-------------------------|-----------------|---|
| Complete Cylinder | MDM2E20-50A-M9B | Cylinder with magnet, air cushion, bore 20, stroke 50, with magnetic switch |
| Magnetic Switch | SW-M9B | 2m cable length Unit/pc |
| Magnetic Switch Bracket | SK-B-20 | This model is the bracket for 20 bore |

Standard Cylinders

MM2 Series

Outline Dimension Drawings (mm)

► Axial foot style (L)

► M□M2WL Bore-Stroke □

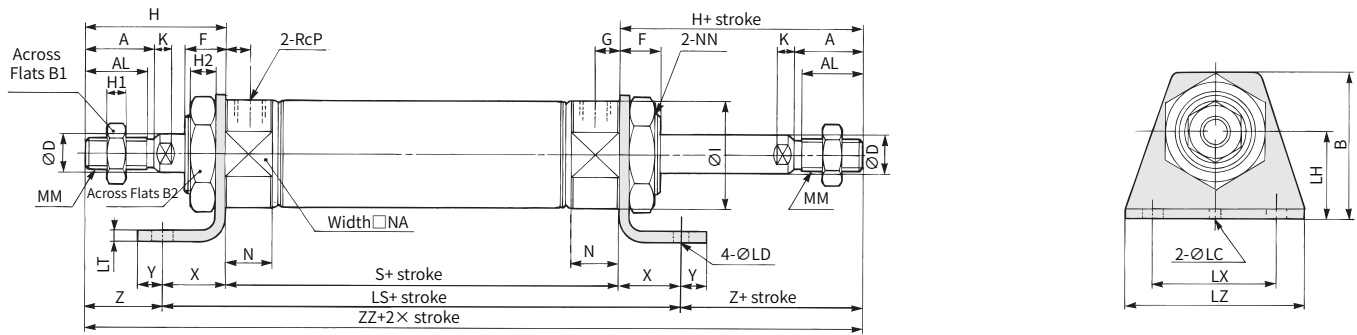

► Adjustable cushion

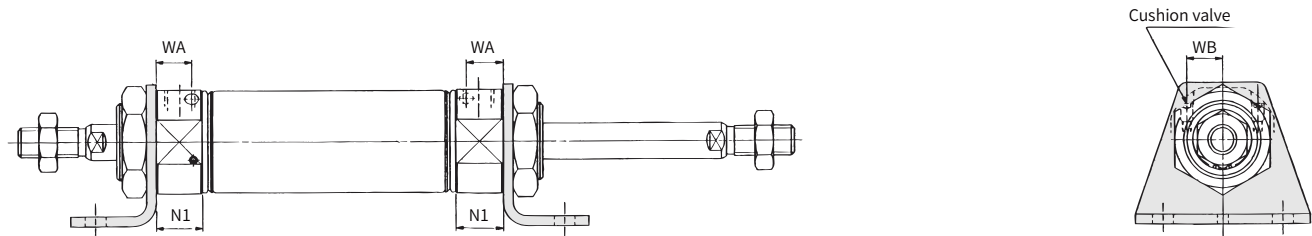

| Bore | A | AL | B | B1 | B2 | D | F | G | H | H1 | H2 | I | K | LC | LD | LH | LS | LT | LX | LZ | MM | N | NA | NN | P | S | X | Y | Z | ZZ |
|------|----|------|----|----|----|----|----|----|----|----|----|------|-----|----|-----|----|-----|----|----|----|----------|------|------|---------|-----|----|----|----|----|-----|
| 20 | 18 | 15.5 | 40 | 13 | 26 | 8 | 13 | 8 | 41 | 5 | 8 | 28 | 5 | 4 | 6.8 | 25 | 102 | 3 | 40 | 55 | M8×1.25 | 15 | 24 | M20×1.5 | 1/8 | 62 | 20 | 8 | 21 | 144 |
| 25 | 22 | 19.5 | 47 | 17 | 32 | 10 | 13 | 8 | 45 | 6 | 8 | 33.5 | 5.5 | 4 | 6.8 | 28 | 102 | 3 | 40 | 55 | M10×1.25 | 15 | 30 | M26×1.5 | 1/8 | 62 | 20 | 8 | 25 | 152 |
| 32 | 22 | 19.5 | 47 | 17 | 32 | 12 | 13 | 8 | 45 | 6 | 8 | 37.5 | 5.5 | 4 | 6.8 | 28 | 104 | 3 | 40 | 55 | M10×1.25 | 15 | 34.5 | M26×1.5 | 1/8 | 64 | 20 | 8 | 25 | 154 |
| 40 | 24 | 21 | 54 | 22 | 41 | 14 | 16 | 11 | 50 | 8 | 10 | 46.5 | 7 | 4 | 7 | 30 | 134 | 3 | 55 | 75 | M14×1.5 | 21.5 | 42.5 | M32×2 | 1/4 | 88 | 23 | 10 | 27 | 188 |

► Adjustable cushion

| Bore | N1 | WA | WB |
|------|------|----|------|
| 20 | 17.5 | 13 | 8.5 |
| 25 | 17 | 13 | 10.3 |
| 32 | 17.5 | 13 | 11.5 |
| 40 | 21.5 | 16 | 15 |

Standard Cylinders

MM2 Series

Outline Dimension Drawings (mm)

▶ Rod side flange style (F)

▶ M□M2WF Bore-Stroke □

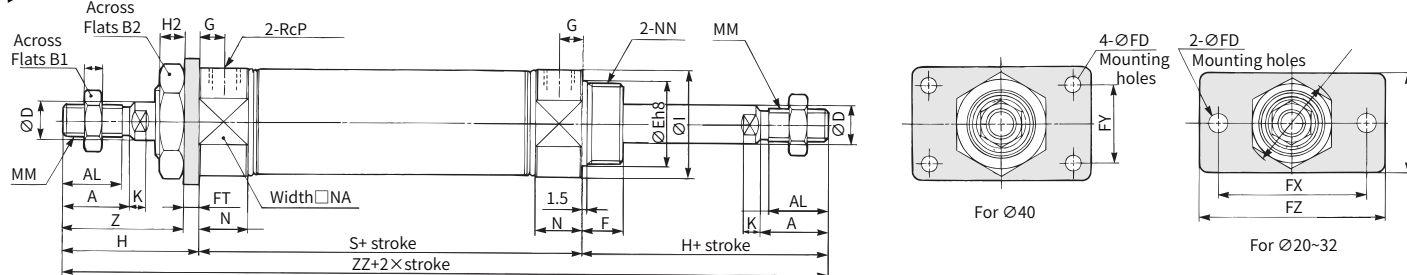

▶ Adjustable cushion

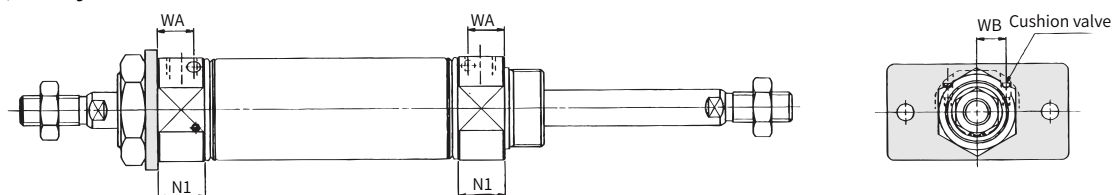

| Bore | A | AL | B | B1 | B2 | C2 | D | E | F | FD | FT | FX | FY | FZ | G | H | H1 | H2 | I | K | MM | N | NA | NN | P | S | Z | ZZ |
|------|----|------|----|----|----|------|----|----------------------------------|----|----|----|----|----|----|----|----|----|----|------|-----|----------|------|------|---------|-----|----|----|-----|
| 20 | 18 | 15.5 | 34 | 13 | 26 | 30 | 8 | 20 ⁰ _{0.033} | 13 | 7 | 4 | 60 | - | 75 | 8 | 41 | 5 | 8 | 28 | 5 | M8×1.25 | 15 | 24 | M20×1.5 | 1/8 | 62 | 37 | 144 |
| 25 | 22 | 19.5 | 40 | 17 | 32 | 37 | 10 | 26 ⁰ _{0.033} | 13 | 7 | 4 | 60 | - | 75 | 8 | 45 | 6 | 8 | 33.5 | 5.5 | M10×1.25 | 15 | 30 | M26×1.5 | 1/8 | 62 | 41 | 152 |
| 32 | 22 | 19.5 | 40 | 17 | 32 | 37 | 12 | 26 ⁰ _{0.033} | 13 | 7 | 4 | 60 | - | 75 | 8 | 45 | 6 | 8 | 37.5 | 5.5 | M10×1.25 | 15 | 34.5 | M26×1.5 | 1/8 | 64 | 41 | 154 |
| 40 | 24 | 21 | 52 | 22 | 41 | 47.3 | 14 | 32 ⁰ _{0.039} | 16 | 7 | 5 | 66 | 36 | 82 | 11 | 50 | 8 | 10 | 46.5 | 7 | M14×1.5 | 21.5 | 42.5 | M32×2 | 1/4 | 88 | 45 | 188 |

▶ Adjustable cushion

| Bore | N1 | WA | WB |
|------|------|----|------|
| 20 | 17.5 | 13 | 8.5 |
| 25 | 17 | 13 | 10.3 |
| 32 | 17.5 | 13 | 11.5 |
| 40 | 21.5 | 16 | 15 |

Other Cylinder Types Model

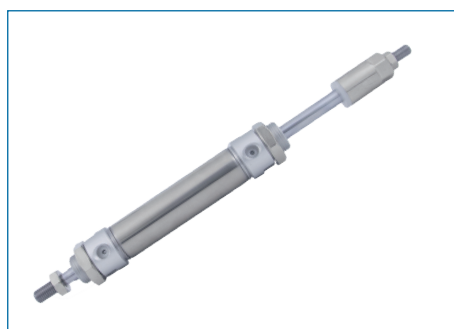

MM2 B Bore - Stroke - XC8 A

| 1 Stroke Adjustment Code | |
|--------------------------|------------------|
| Code | Adjustment Range |
| A | 0-25mm |
| B | 0-50mm |

| Stroke Adjustable Cylinder (Extend Adjustable Type) | |
|---|--------|
| Adjustment Range | 0-50mm |