

Liquid Injection Valve VNP Series



Standard Specifications

Model	15A-VNP-40DF
Working Fluid	Air, Water, Low Viscosity Liquids
Control Pressure	300~600Kpa
Inlet Port Pressure	-101~500Kpa ^{Note}
Outlet Port Pressure	-101~500Kpa
Operating Ambient Temperature	5~60°C
Flow Passage Diameter	Ø6
Max Vacuum Flow Rate (-100)	100L/min(Air)
Max Positive Pressure Flow Rate	500L/min(Air)

Note: When the liquid injection valve is closed, port A can withstand a maximum pressure of 1MPa.

Model Code System



① Copper-Free			② Product Series			
Copper-Free Series 15A			VNP			
③ Control Part Cylinder Diameter						
32			Bore Diameter Ø32 <small>(Valid only for some models)</small>			
40			Bore Diameter Ø40			
④ Control Part Cylinder Material						
D			Stainless Steel			
⑤ Valve Body Connection Method - Specifications and Corresponding						
Interface Type	Type Model	Specification	Valve Body Bore Diameter			
			4.5mm	6mm	8mm	11mm
F: Flange Interface	Blank	Four-hole flange	×	●	●	●
	3	Three-hole flange	×	●	●	●
	8	8-hole M3 flange	×	●	●	●
Interface Type	Type Model	Specification	Valve Body Bore Diameter			
			imperial units inch	OD	4.5mm	6mm
K: Ferrule fitting	4S	1/4"	●	×	×	×
	6S	3/8"	×	×	●	×
	8S	1/2"	×	×	×	●
	Metric units	OD	4.5mm	6mm	8mm	11mm
	6	Ø6	●	×	×	×
	8	Ø8	×	●	×	×
	10	Ø10	×	×	●	×
12	Ø12	×	×	×	●	
Interface Type	Type Model	Specification	Valve Body Bore Diameter			
			4.5mm	6mm	8mm	11mm
HR (Inlet: RC female thread swivel connector, Outlet: fixed connector)	02	RC1/4	×	●	×	×
	03	RC3/8	×	×	●	×
	04	RC1/2	×	×	×	●
⑥ Does the valve body come with an open/close detection sensor						
Blank			None			
A			with open/close detection sensor			
⑦ Valve body through-hole diameter (only for flange type, optional)						
Blank			6mm			
8			8mm			
11			11mm			
⑧ Maximum fluid operating pressure (only for valve body with 6mm bore size, optional)						
Blank			0.5Mpa			
1M			1.0Mpa			

Liquid Injection Valve

VNP Series

Common Problems

Reduced flow rate	Crystallization inside the valve
Valve body blocked	Insufficient cylinder pressure
	Cylinder damaged
Valve cannot close completely	Crystallization inside the valve
	Foreign matter entering the valve, valve port damaged

Usage Precautions

The material of this product has a certain corrosion resistance.
Be careful not to scratch the flow channel during cleaning to prevent fluid crystallization.
This product is a pneumatically operated device. The compressed air must not contain water, other liquids, or dust.
Do not use the product beyond the maximum pressure rating to avoid internal damage.
Do not impact or squeeze the cylinder body to prevent deformation.

Mounting Type

- ▶ 例: 15A-VNP-40DF, 两端法兰盘连接, 两端各两个 $\varnothing 4\text{mm}$ 的定位销深度5mm, 两端各四个螺丝孔(M4*0.7)用于固定, 两端 $\varnothing 11.5\text{mm}$ 深1mm的槽内各放一个内径 $\varnothing 8\text{mm}$, 线径1.5mm的O型密封圈。

Example: 15A-VNP-40DF, flange connection on both ends.
On each end: two 4 mm dowel pins (depth 5 mm), and four screw holes (M4×0.7) for fixing.
In a groove of 11.5 mm (depth 1 mm) on each end, place one O-ring with an inner diameter of 8 mm and a cross-section diameter (wire diameter) of 1.5 mm.

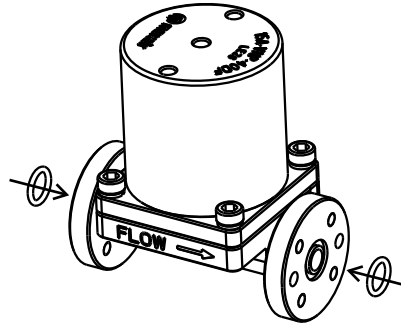

Product Schematic Diagram

- ▶ 此阀是常闭型, 通入正压气源推动活塞向上运动, 活塞缸向上带动膜片向上离开阀口, 阀口被打开, 介质从入口流向出口, 从而实现打开功能; 关闭正压并卸压活塞在弹簧推力作用下, 阀口关闭, 入口到出口通道阻断, 从而实现关闭功能。

No.	Name	Material	No.	Name	Material
1	Spring	SUS304	2	Cylinder body	SUS304
3	Piston seal	FKM	4	Piston	SUS304
5	Diaphragm	PTFE	6	O-ring	FKM
7	Flange	SUS304	8	Valve seat	SUS316L

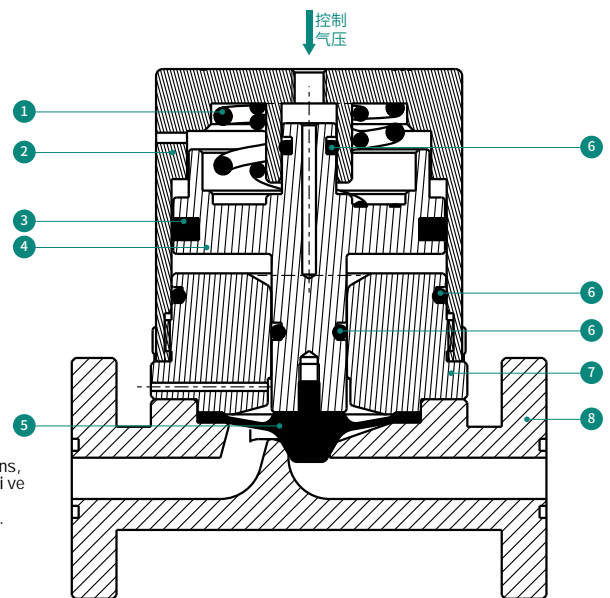

This valve is normally closed. When positive pressure air is applied, the piston moves upward. The piston rod drives the diaphragm upward, lifting it away from the valve port. The valve port opens, and the medium flows from the inlet to the outlet, thus achieving the open function. When the positive pressure is removed and the system is vented, the piston is pushed downward by the spring force. The valve port closes, blocking the passage from inlet to outlet, thus achieving the close function.

Technical Specifications

Cylinder air port fitting: M5
Cylinder operating pressure: 350 kPa ~ 600 kPa
Inlet operating pressure: -101 kPa ~ 500 kPa
Outlet operating pressure: -101 kPa ~ 500 kPa

注液阀

VNP系列

Installation and Operating Instructions for VNP Series Liquid Injection Valve (Diaphragm Valve)

► Product Classification Introduction

DF Series (Flange mounting surface on both ends, groove requires corrosion-resistant EPDM O-ring)

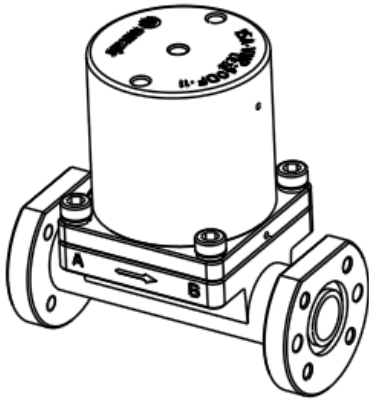

Without position feedback sensor

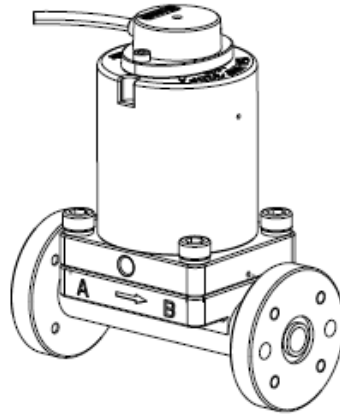

With position feedback sensor

► DK Series (Equipped with double ferrule nut assemblies on both ends. First, slide the nut, back ferrule, and front ferrule onto the tube in that order, then insert the tube into the end connection port of the valve, and tighten the nut.)

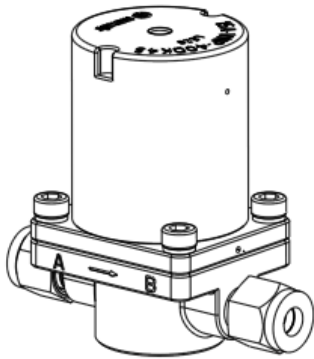

Without position feedback sensor

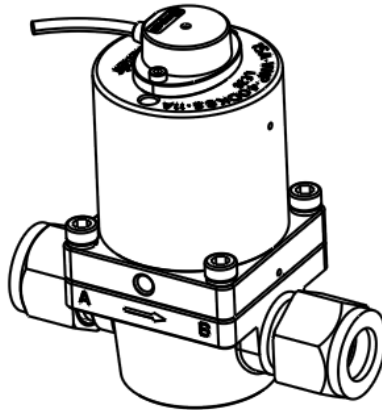

With position feedback sensor

► DG(R) Series (G (RC) threads on both ends. Both ends can accept G (R) thread fittings. For G thread holes, a corrosion-resistant PTFE washer is required for sealing.)

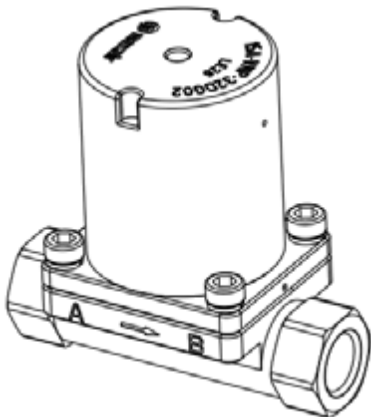

Both ends with female pipe thread G1/4.

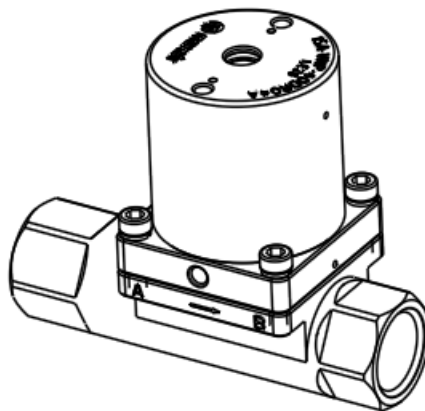

Both ends with female pipe thread RC1/2

注液阀

VNP系列

Installation and Operating Instructions for VNP Series Liquid Injection Valve (Diaphragm Valve)

Parameter Introduction

Control method	Clean air
Action mode	Normally closed
Applicable fluids	Air, water, electrolyte
Applicable temperature	-10°C ~ 60°C (do not freeze at low temperature)
Control air pressure	300 kPa – 600 kPa (for some models)
	400 kPa – 600 kPa (for others, except 1 MPa)
Inlet fluid operating pressure	-101 kPa ~ 500 kPa (except 1 MPa)
Outlet fluid operating pressure	-101 kPa ~ 350 kPa (except 1 MPa)
Bore diameter	φ 6mm, φ 8mm, φ 11mm
Valve body leakage standard	No dripping (for 1 minute)
Position feedback NPN switch	DC24 V, NPN switch signal (optional)

Installation Instructions (Ensure no impurities or particles remain in the pipeline before installation)

The side marking A → B Or FLOW →

→ indicates the fluid flow direction under positive pressure only.

The positive pressure at port A must not exceed 500 kPa, and the positive pressure at port B must not exceed 350 kPa.

If used in an environment with both positive and negative pressures, port B must be connected to a positive pressure source, and the pressure must not exceed 350 kPa.

Example:

① Installation condition

Used only under positive pressure, with positive pressure at port A not exceeding 500 kPa and at port B not exceeding 350 kPa.

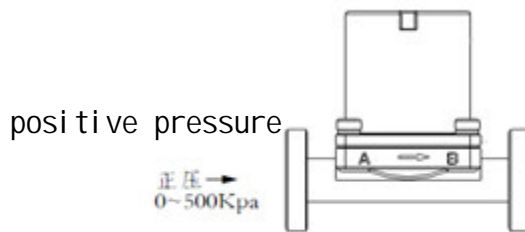

② Installation condition

In an environment where positive pressure (not exceeding 350 kPa) is applied to one port, and negative pressure exists at the other port.

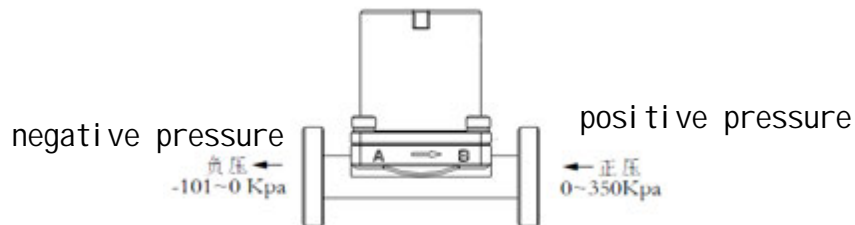

③ Installation condition

In an environment where one end is subjected to alternating positive and negative pressure (with the positive pressure not exceeding 350 kPa), and the other end is under negative pressure.

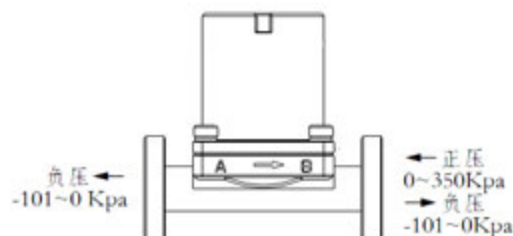

注液阀 **VNP系列**

Outline dimension drawing

► 15A-VNP-40DF3-1M(B)

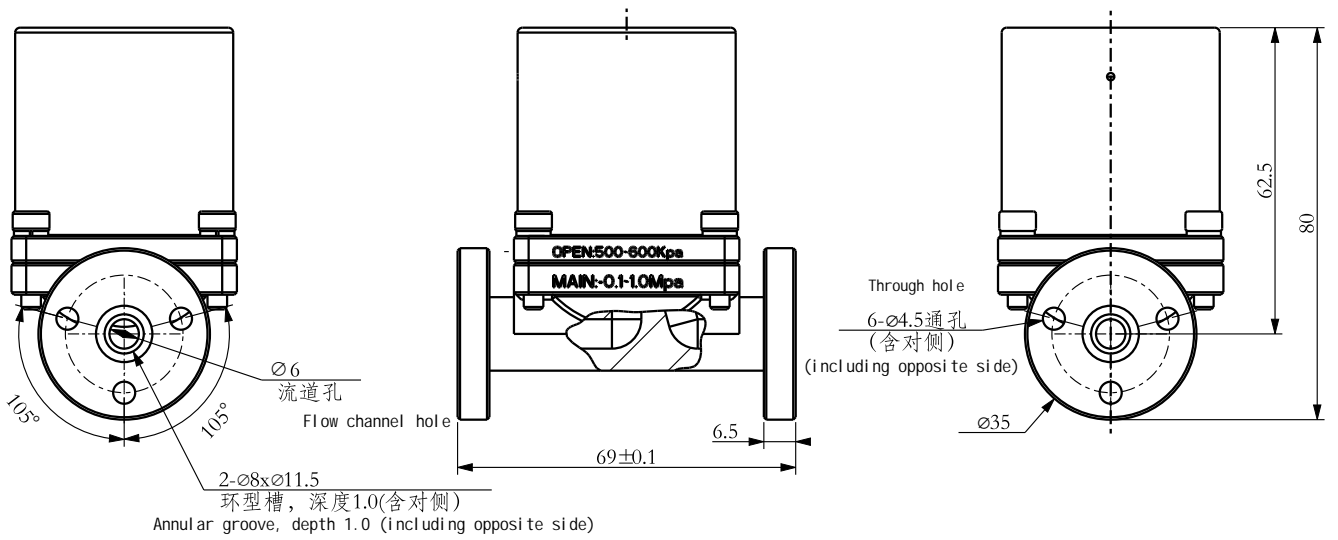

两端配O型圈内径 $\phi 8$ *线径1.5的EPDM
 Equipped with EPDM O-rings
 (inner diameter $\phi 8$ mm \times cross-section diameter 1.5 mm)
 on both ends.

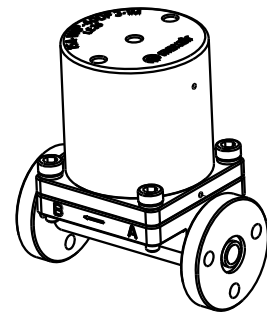
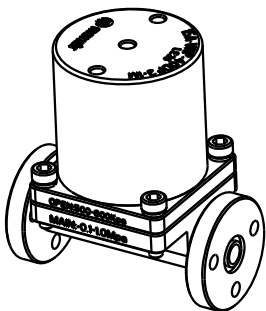
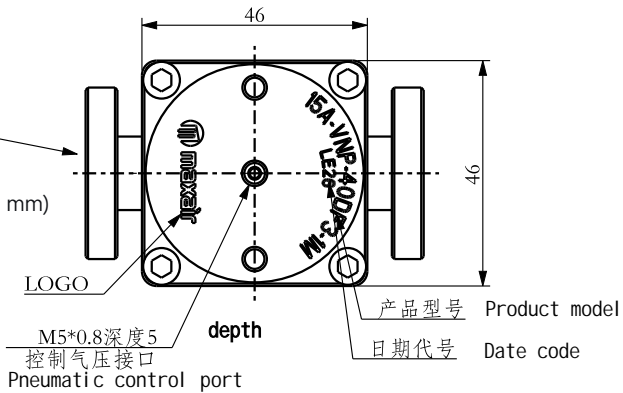

注液阀

VNP系列

外观尺寸图

► 15A-VNP-40DF3A-1M(B)

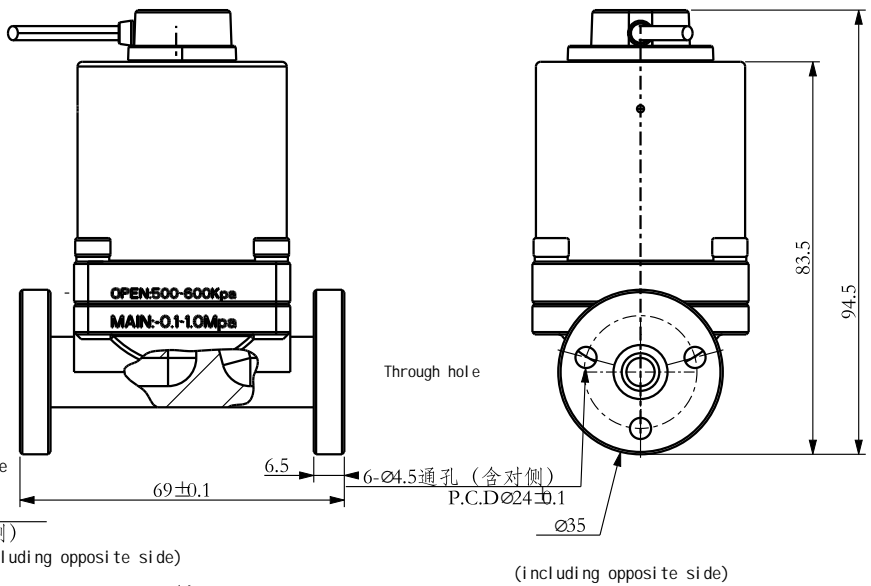
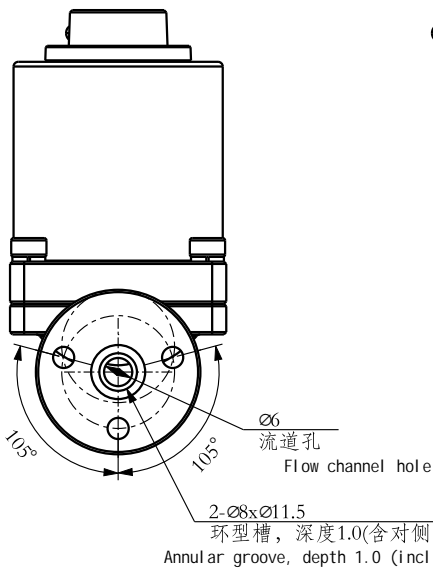
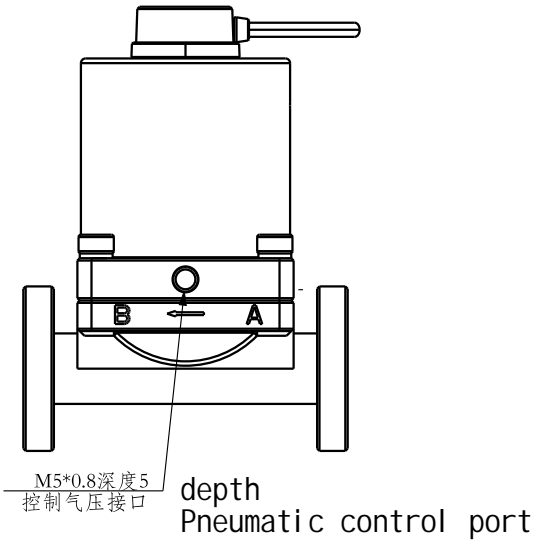

两端配O型圈内径Ø8, 线径1.5
Equipped with O-rings (inner diameter Ø8 mm, cross-section diameter 1.5 mm) on both ends.

位置反馈传感器

Position feedback sensor

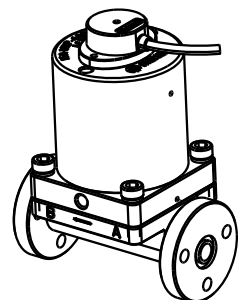
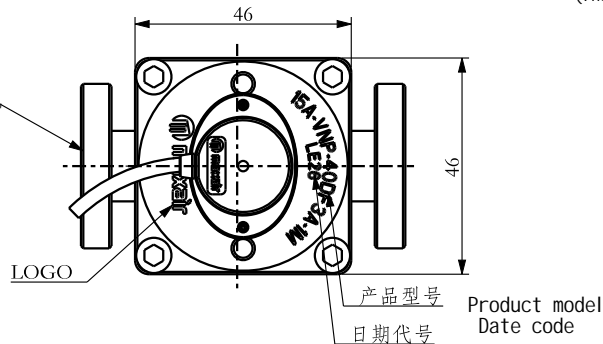
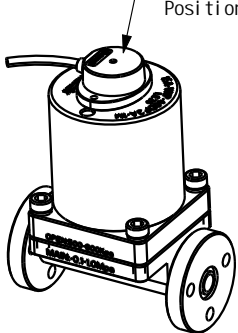

注液阀 VNP系列

外观尺寸图

► 15A-VNP-40DF3A-1M-FL231028-104(A)

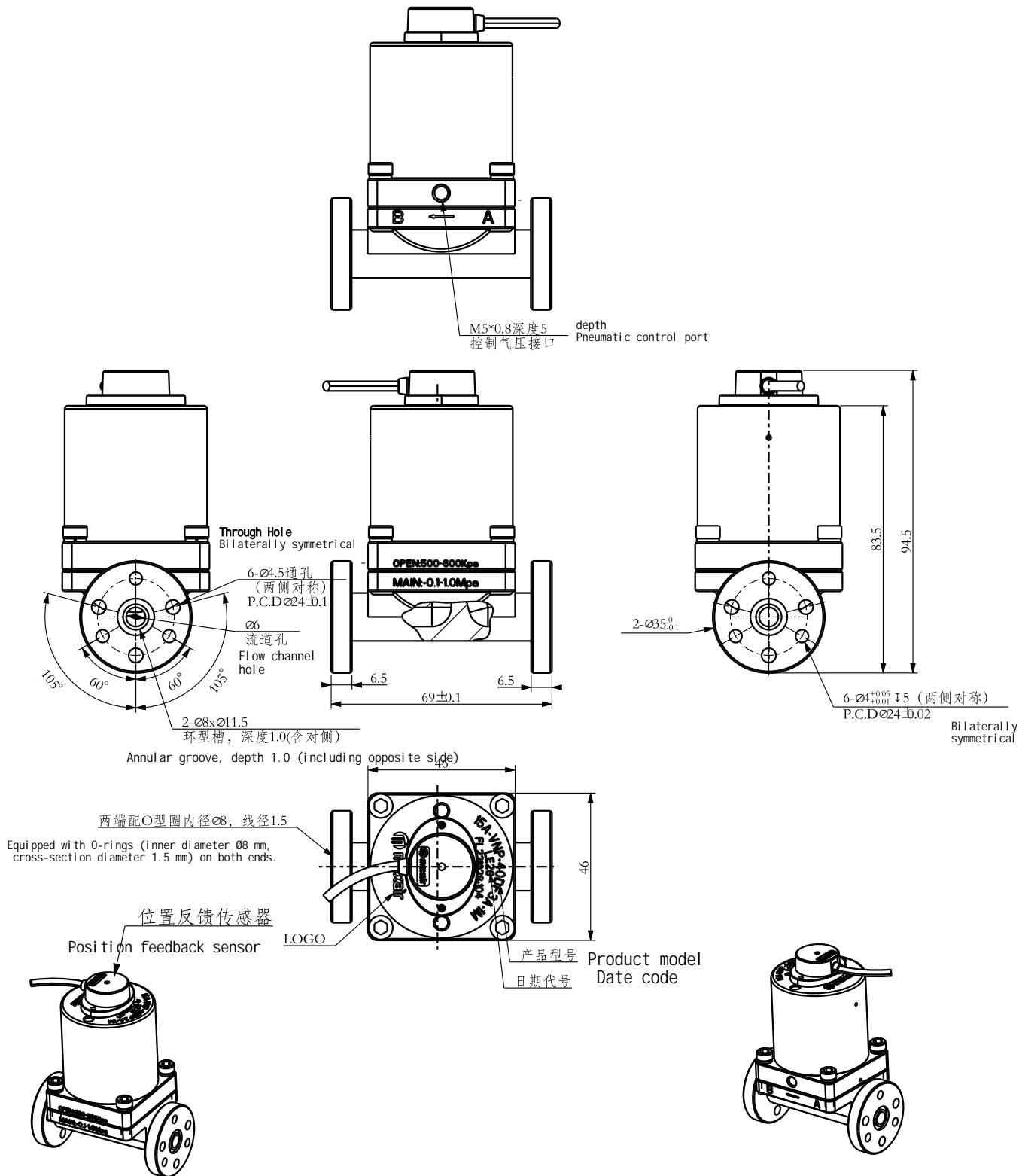

注液阀

VNP系列

Outline dimension drawing

► 15A-VNP-40DF-11(C)

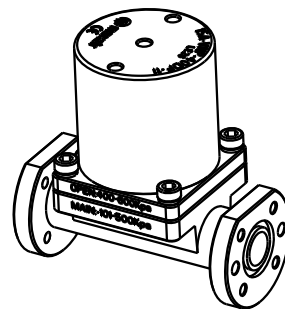
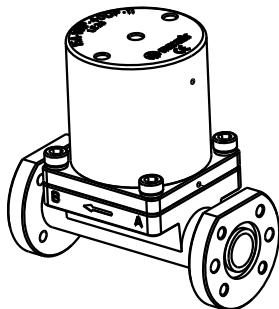
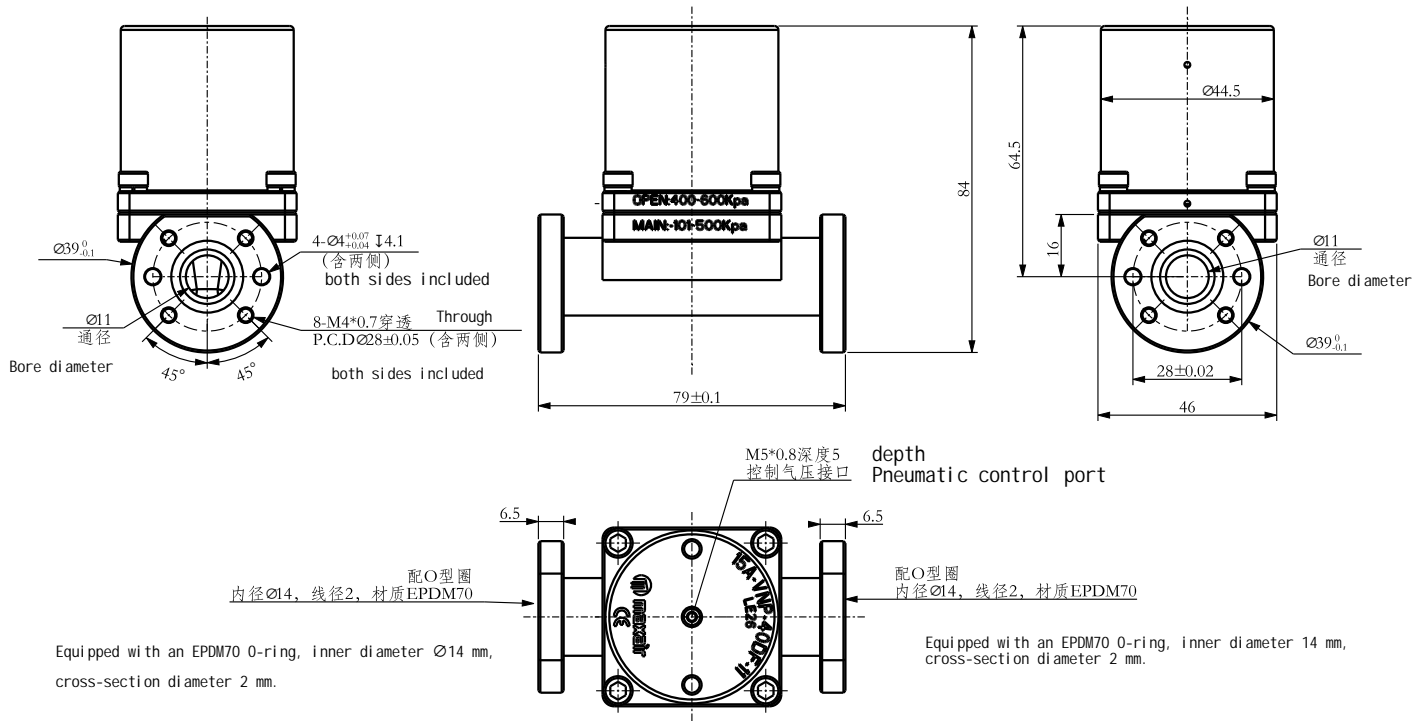

注液阀 VNP系列

外观尺寸图

► 15A-VNP-40DFA-8(B)

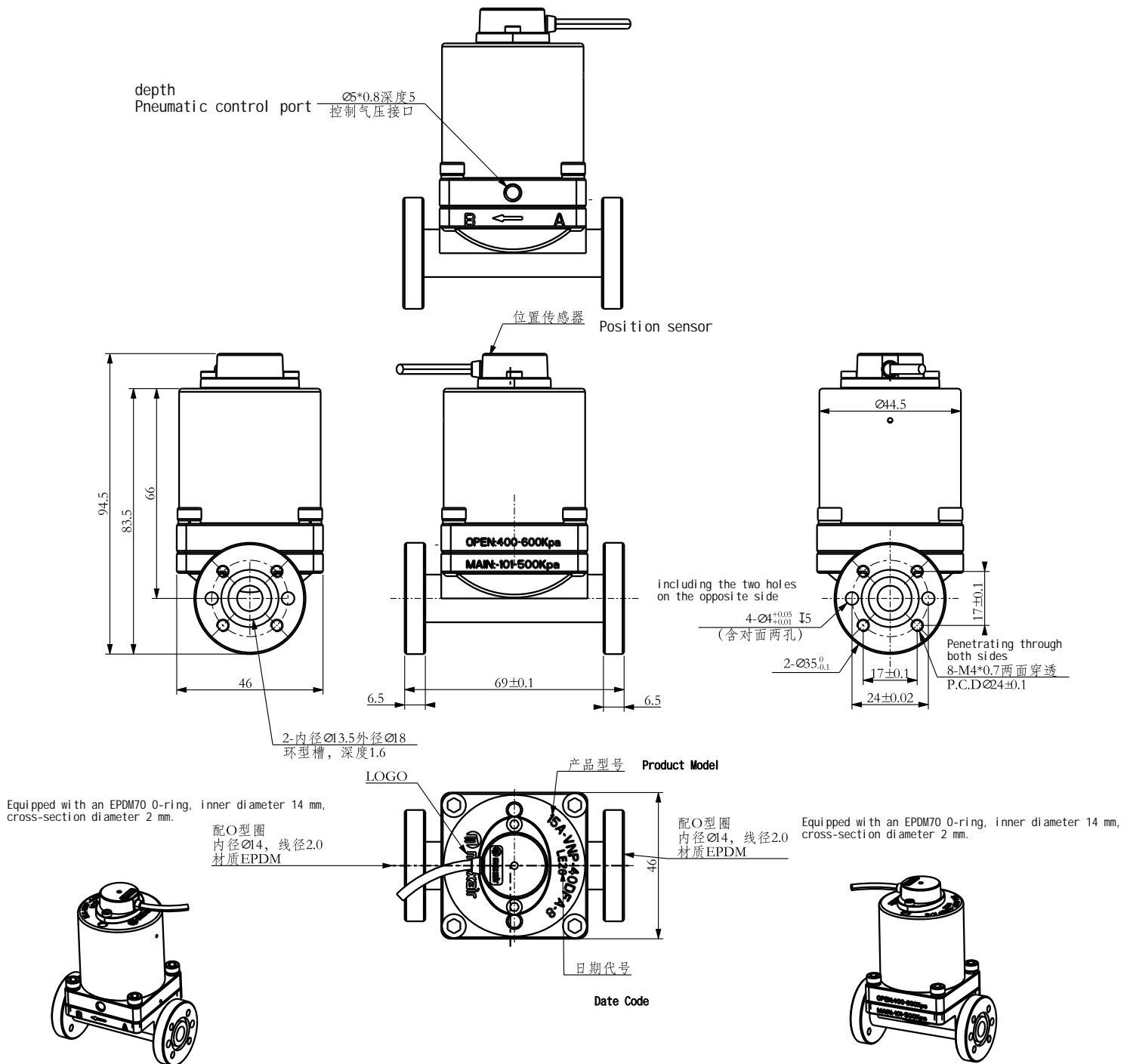

注液阀

VNP系列

外观尺寸图

► 15A-VNP-40DFA-8-FL231020-84(B)

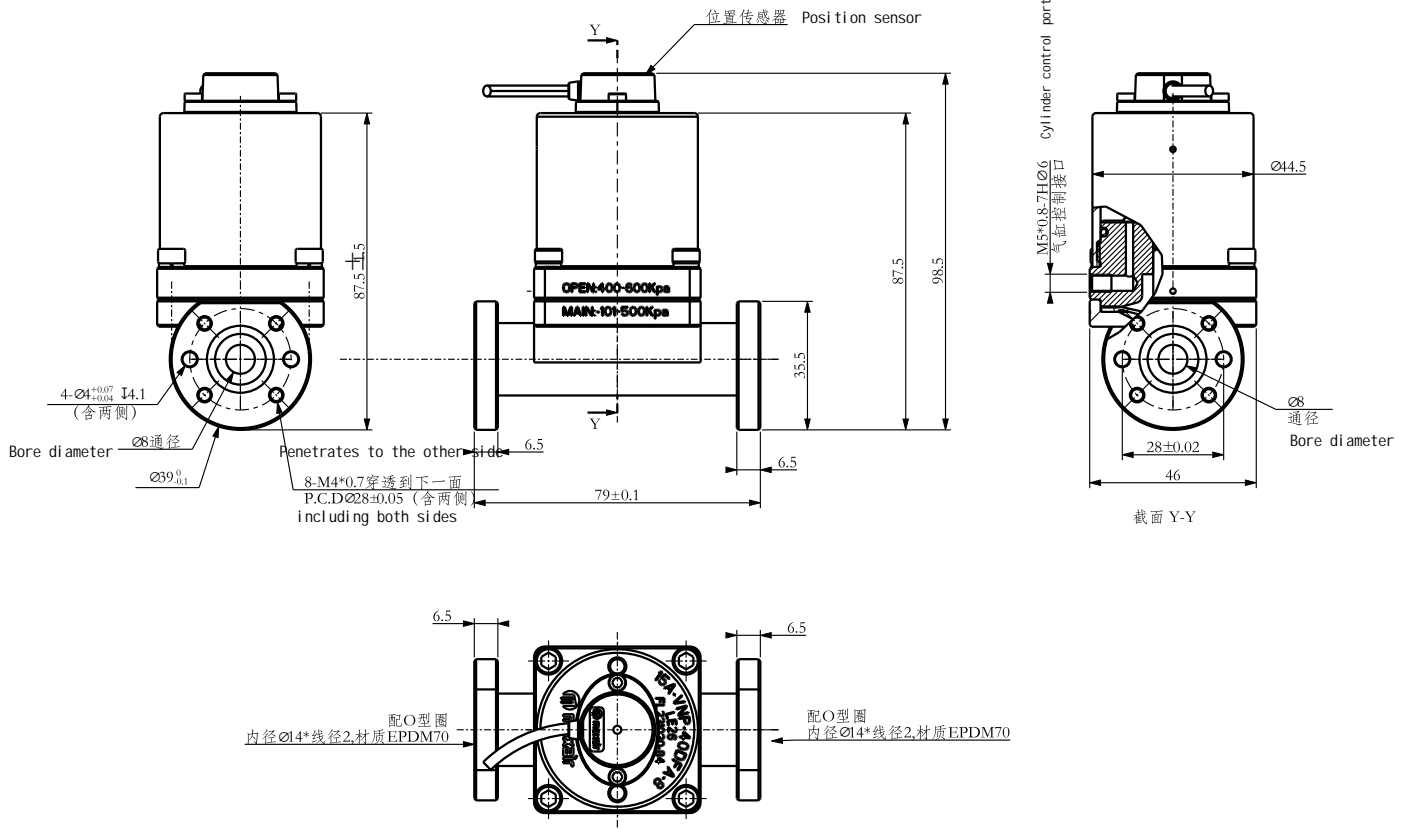

Equipped with an EPDM70 O-ring, inner diameter $\varnothing 14$ mm, cross-section diameter 2 mm.

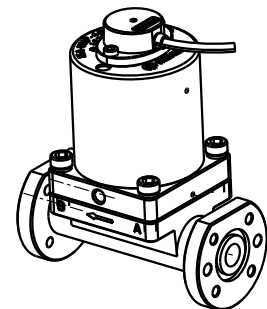
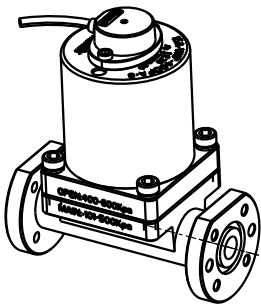

注液阀

VNP系列

外观尺寸图

► 15A-VNP-40DFA-11(C)

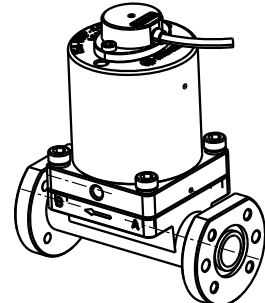
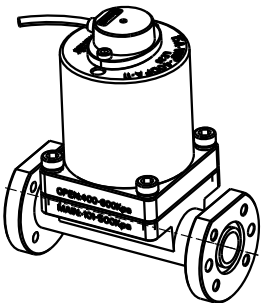
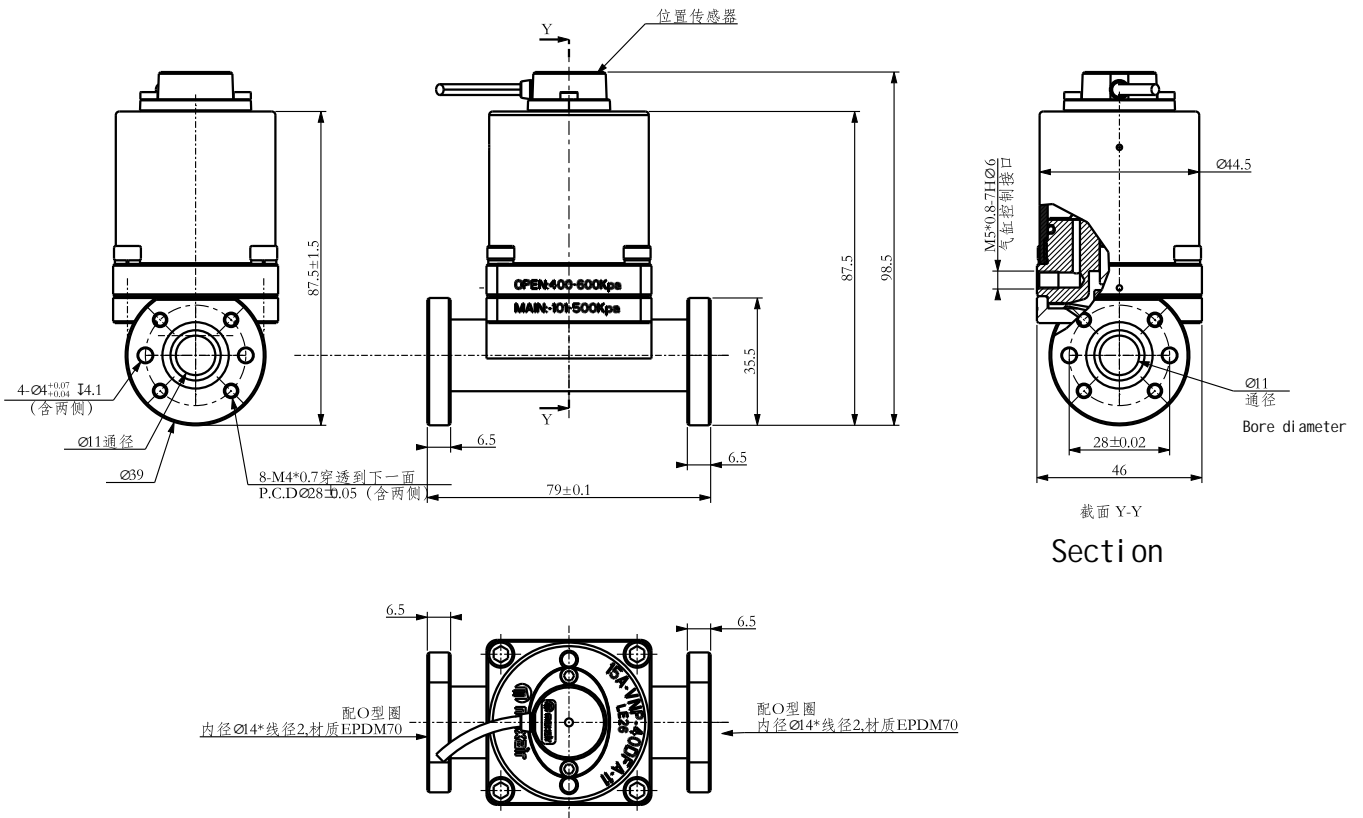

注液阀

VNP系列

外观尺寸图

► 15A-VNP-40DG04A(C)

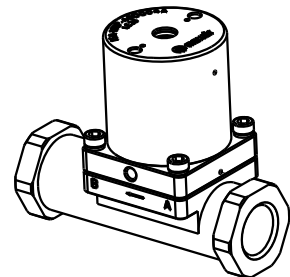
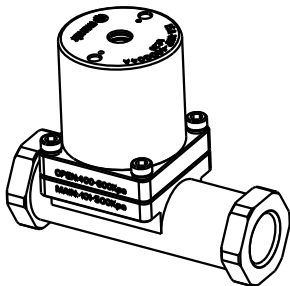
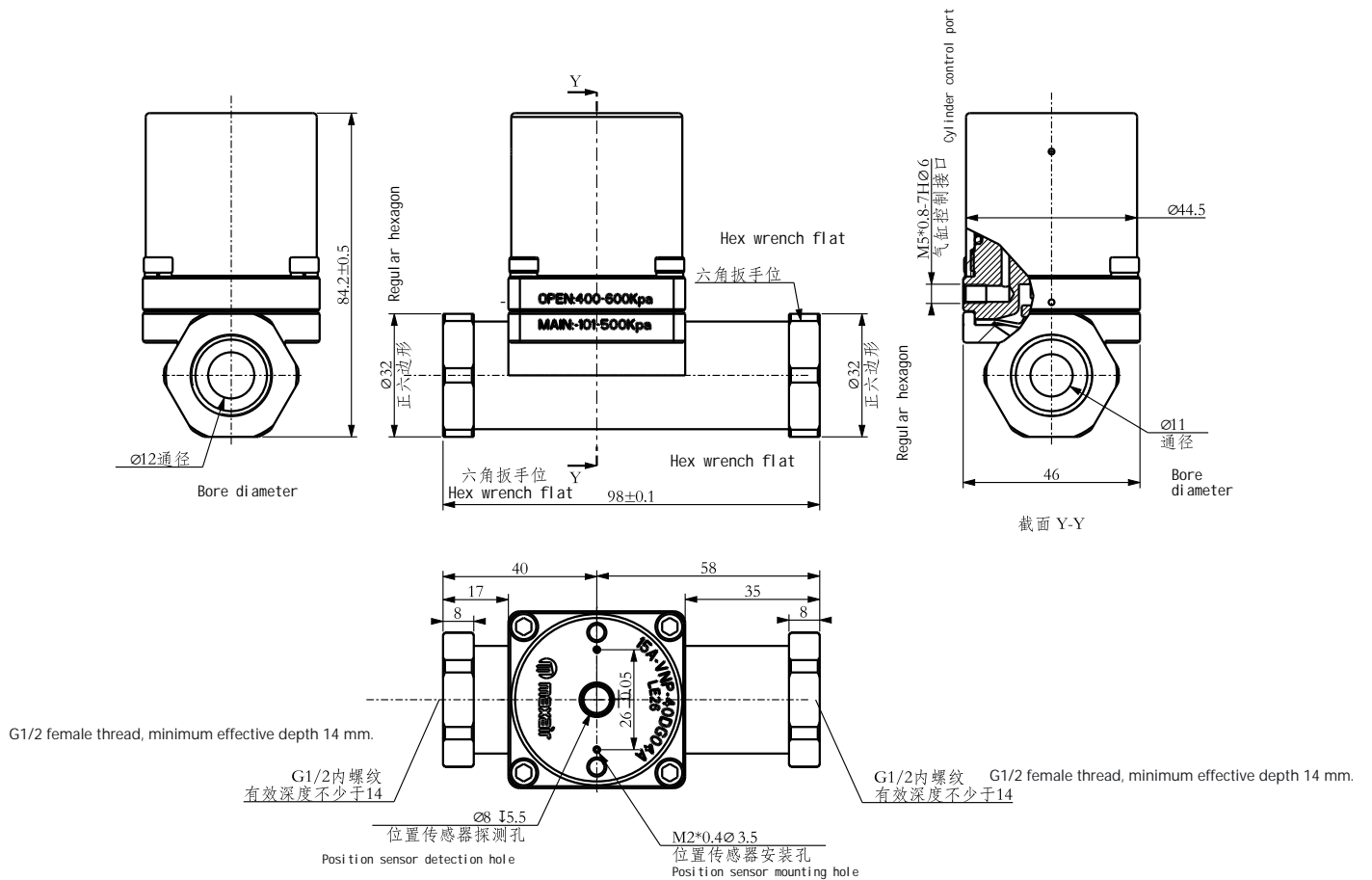

注液阀 **VNP系列**

外观尺寸图

▶ 15A-VNP-40DHR04A(B)

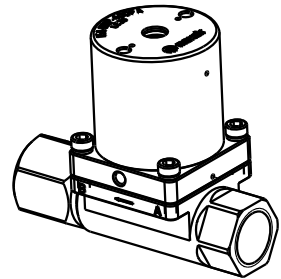
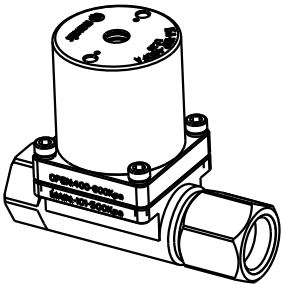
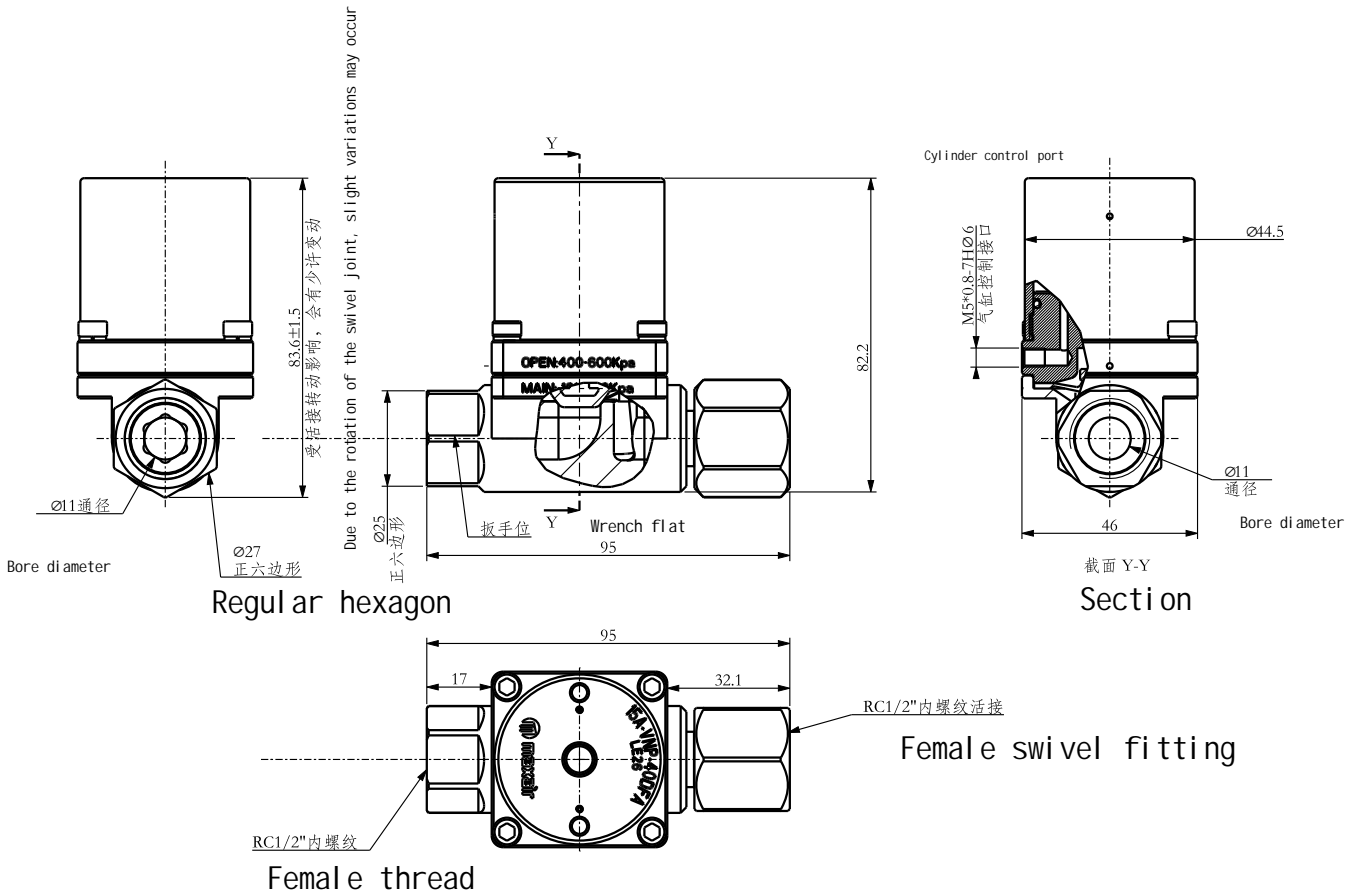

注液阀

VNP系列

外观尺寸图

► 15A-VNP-40DK6S(B)

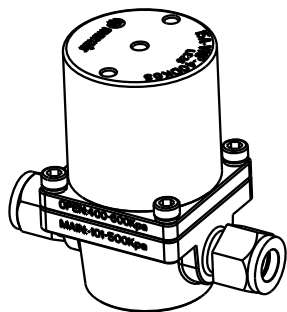
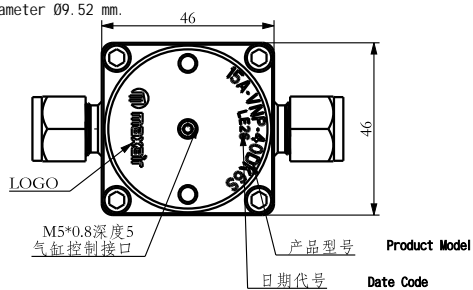
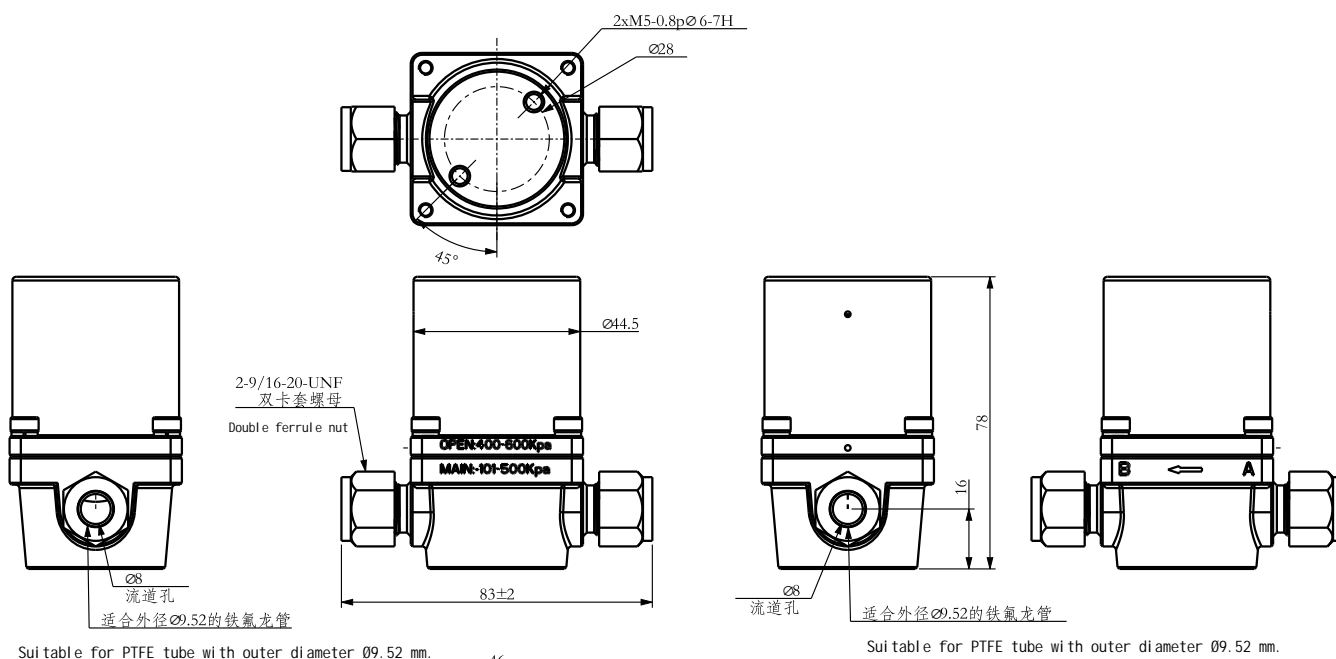

流道孔: Flow hole
 气缸控制接口: Cylinder control port
 产品型号: Product Model
 日期代号: Date Code
 双卡套螺母: Double ferrule nut
 适合外径XX的铁氟龙管: ui table for PTFE tube with outer diameter XX mm.

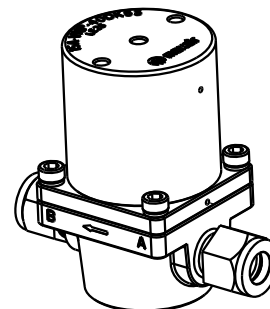

注液阀

VNP系列

外观尺寸图

► 15A-VNP-40DK6SA(B)

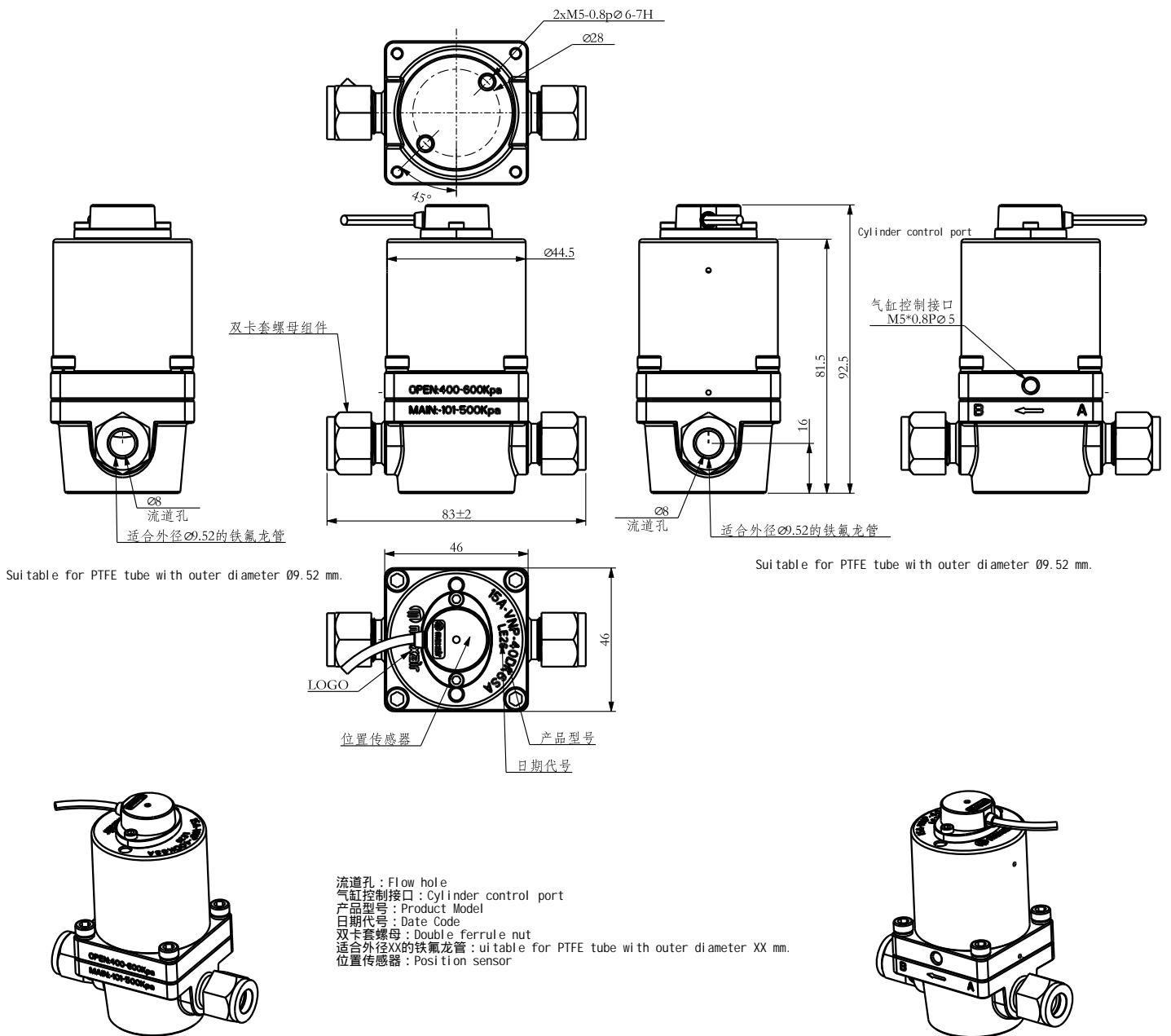

注液阀

VNP系列

外观尺寸图

► 15A-VNP-40DK8-1M(B)

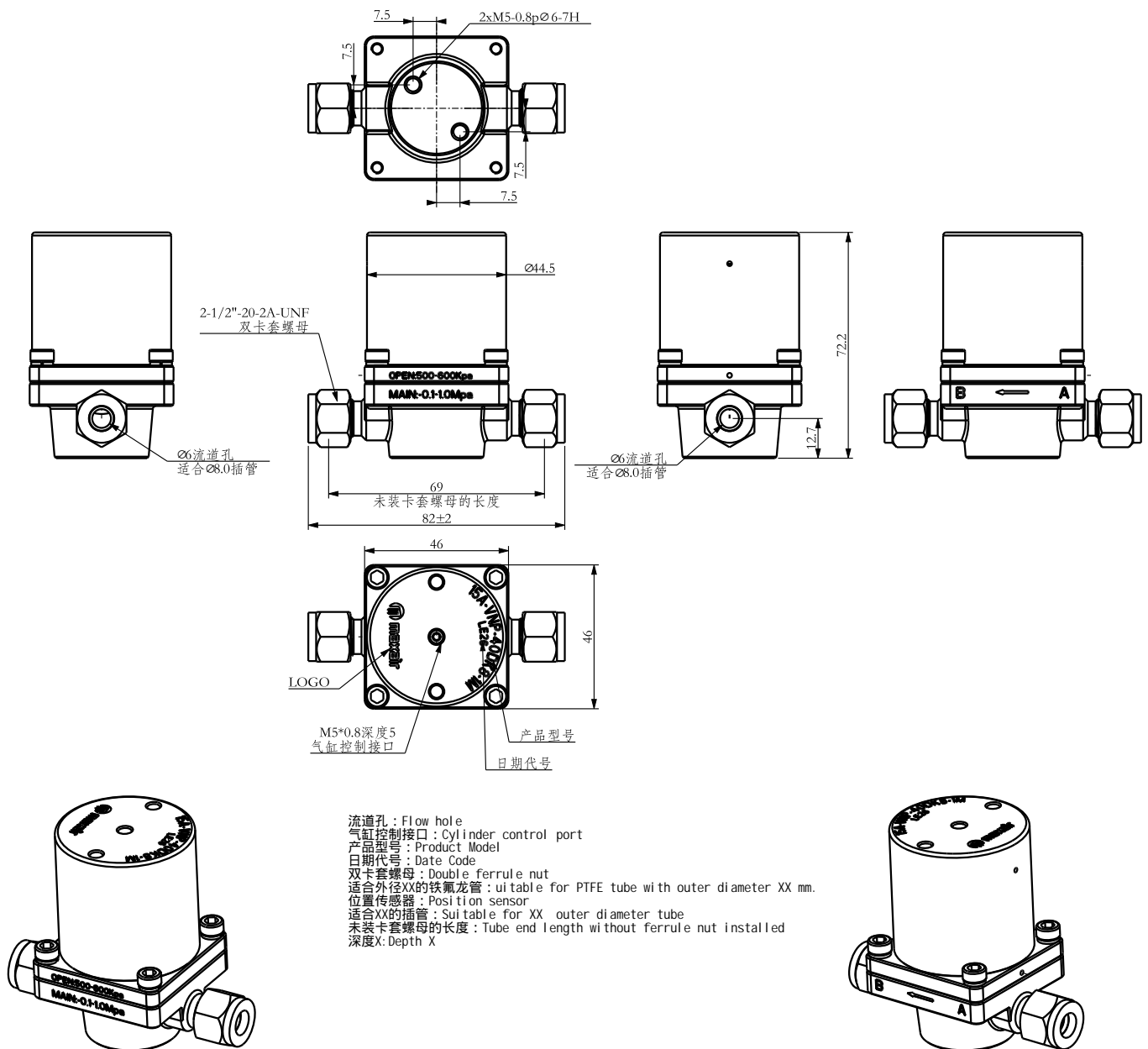

注液阀

VNP系列

外观尺寸图

► 15A-VNP-40DK8A-1M(B)

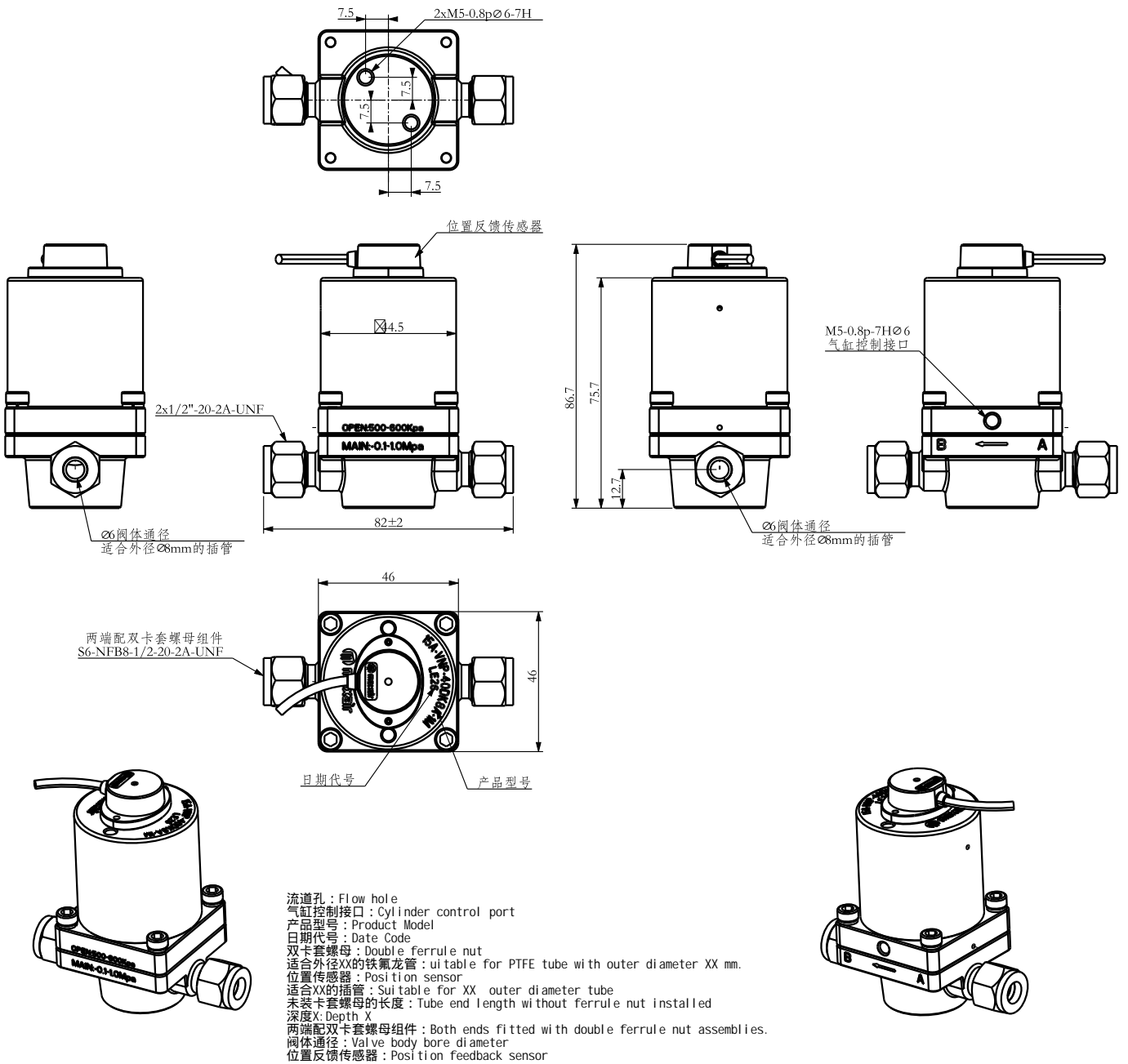

注液阀

VNP系列

外观尺寸图

► 15A-VNP-40DK8S(C)

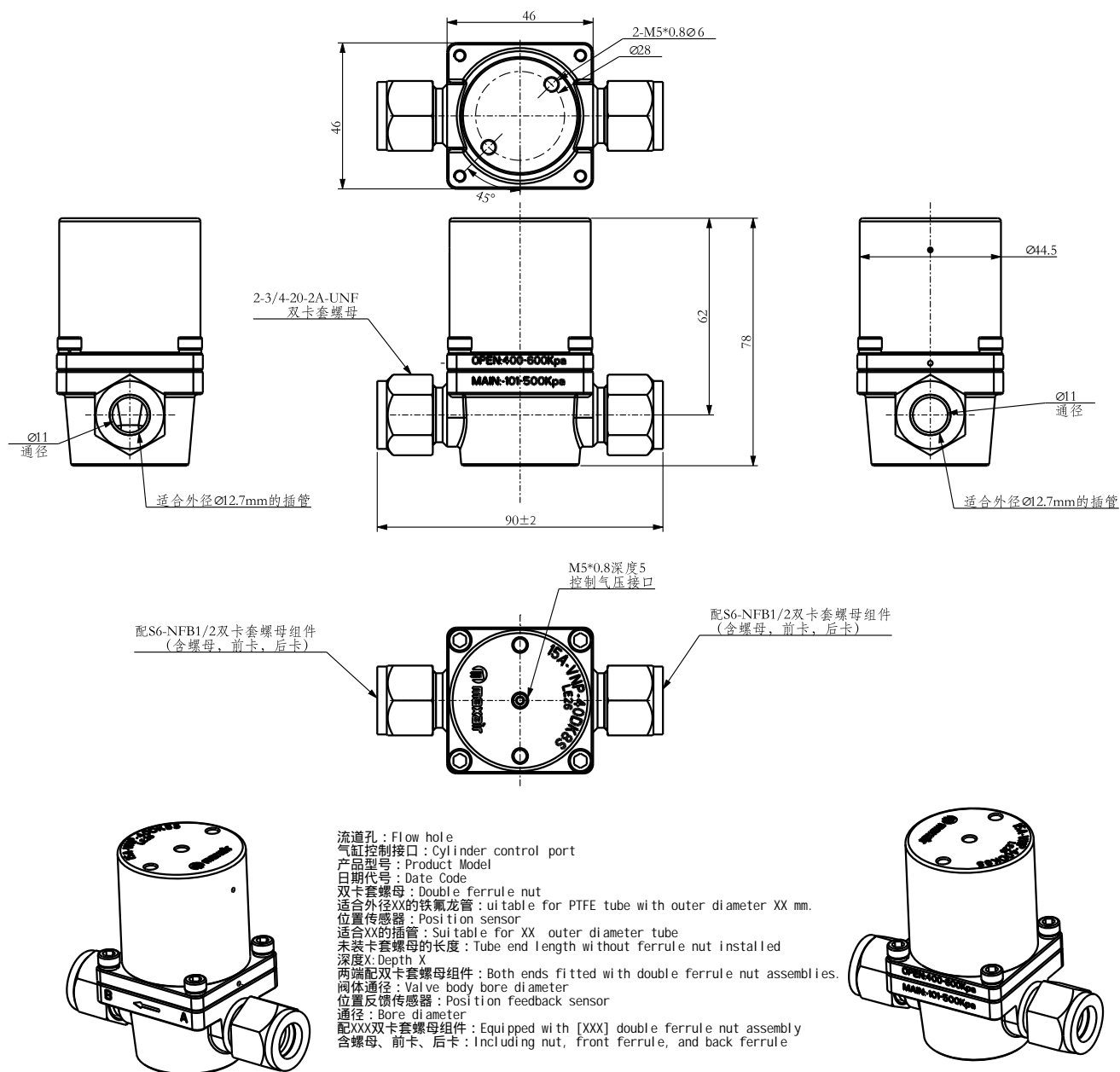

注液阀

VNP系列

外观尺寸图

► 15A-VNP-40DK8SA(D)

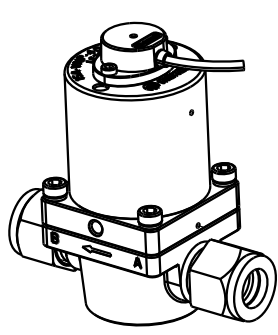
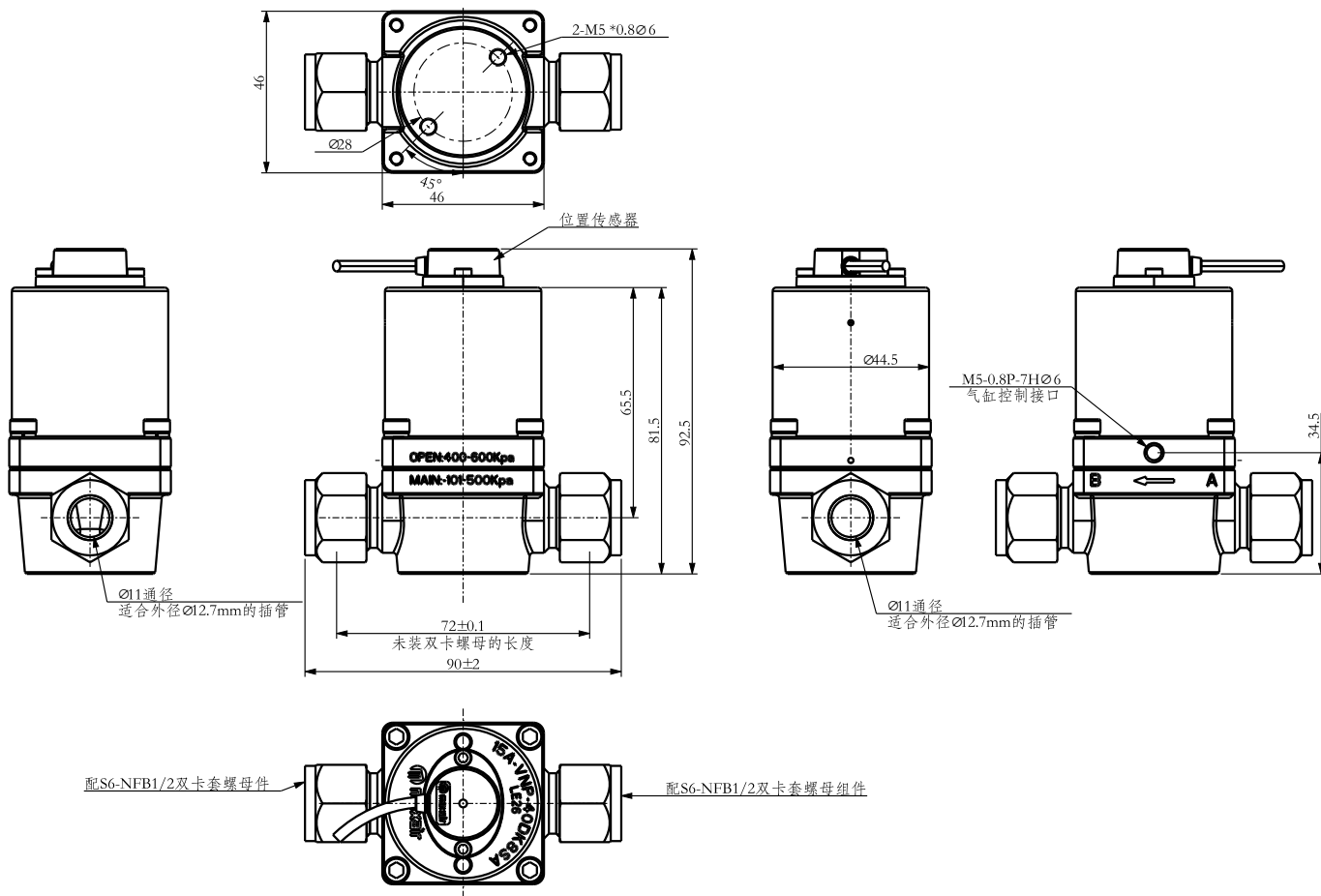

流道孔: Flow hole
 气缸控制接口: Cylinder control port
 产品型号: Product Model
 日期代号: Date Code
 双卡套螺母: Double ferrule nut
 适合外径XX的铁氟龙管: suitable for PTFE tube with outer diameter XX mm.
 位置传感器: Position sensor
 适合XX的插管: Suitable for XX outer diameter tube
 未装卡套螺母的长度: Tube end length without ferrule nut installed
 深度: Depth X
 两端配双卡套螺母组件: Both ends fitted with double ferrule nut assemblies.
 阀体通径: Valve body bore diameter
 位置反馈传感器: Position feedback sensor
 通径: Bore diameter
 配XX双卡套螺母组件: Equipped with [XXX] double ferrule nut assembly
 含螺母、前卡、后卡: Including nut, front ferrule, and back ferrule

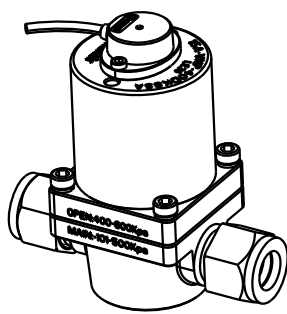

注液阀

VNP系列

外观尺寸图

► 15A-VNP-40DK10(B)

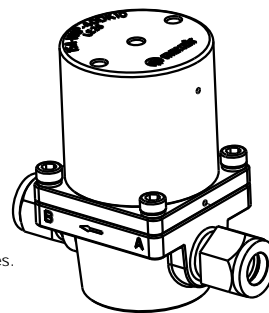
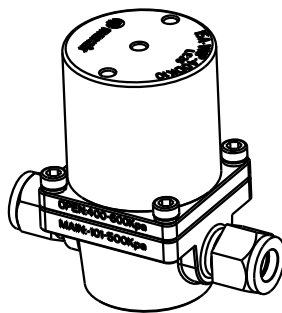
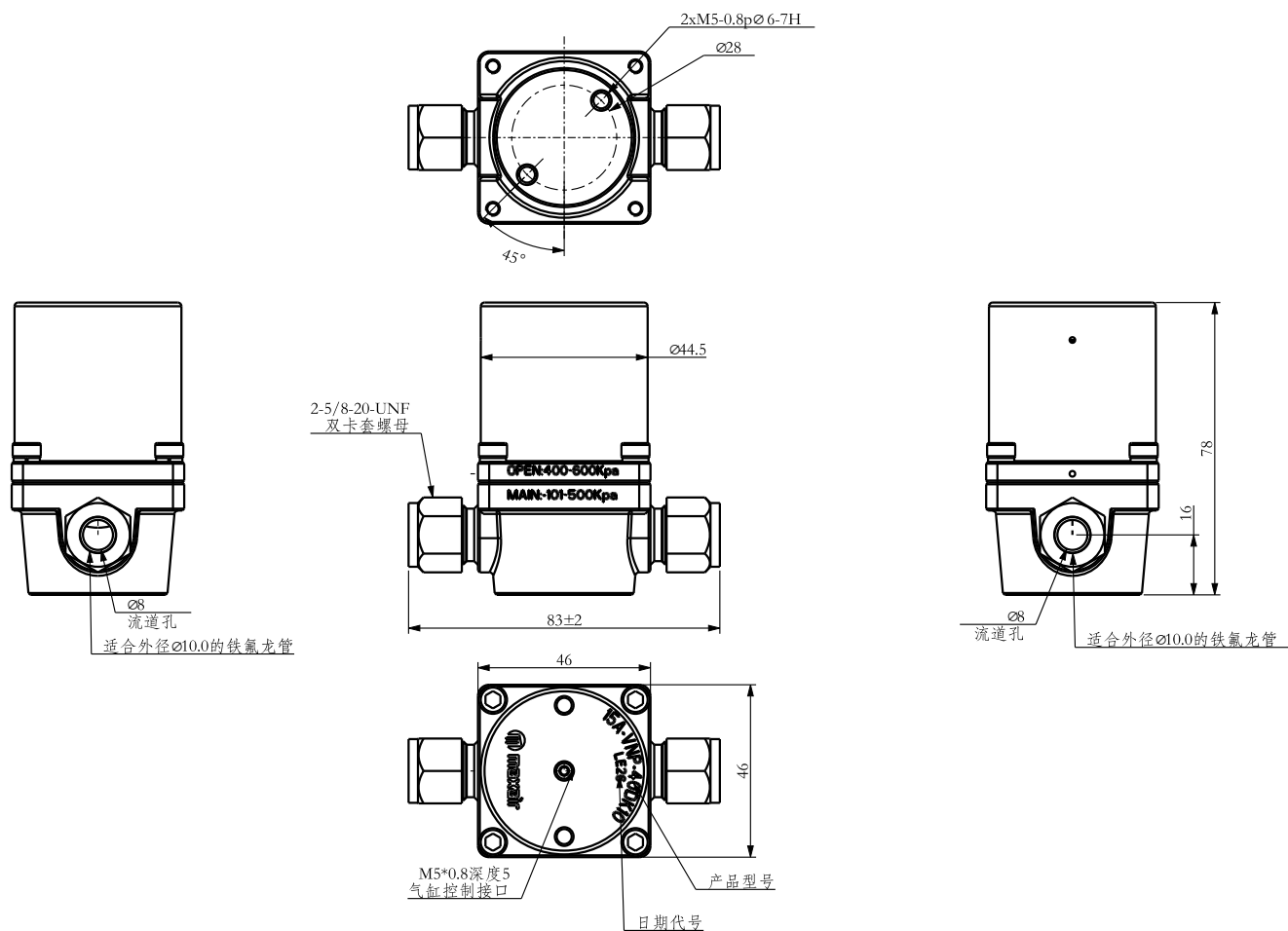

流道孔: Flow hole
 气缸控制接口: Cylinder control port
 产品型号: Product Model
 日期代号: Date Code
 双卡套螺母: Double ferrule nut
 适合外径XX的铁氟龙管: Suitable for PTFE tube with outer diameter XX mm.
 位置传感器: Position sensor
 适合XX的插管: Suitable for XX outer diameter tube
 未装卡套螺母的长度: Tube end length without ferrule nut installed
 深度X: Depth X
 两端配双卡套螺母组件: Both ends fitted with double ferrule nut assemblies.
 阀体通径: Valve body bore diameter
 位置反馈传感器: Position feedback sensor
 通径: Bore diameter
 配XXX双卡套螺母组件: Equipped with [XXX] double ferrule nut assembly
 含螺母、前卡、后卡: Including nut, front ferrule, and back ferrule

注液阀 VNP系列

外观尺寸图

► 15A-VNP-40DK10A(B)

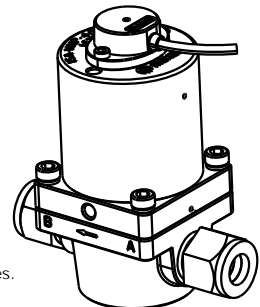
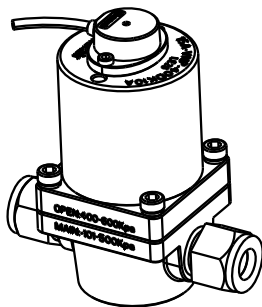
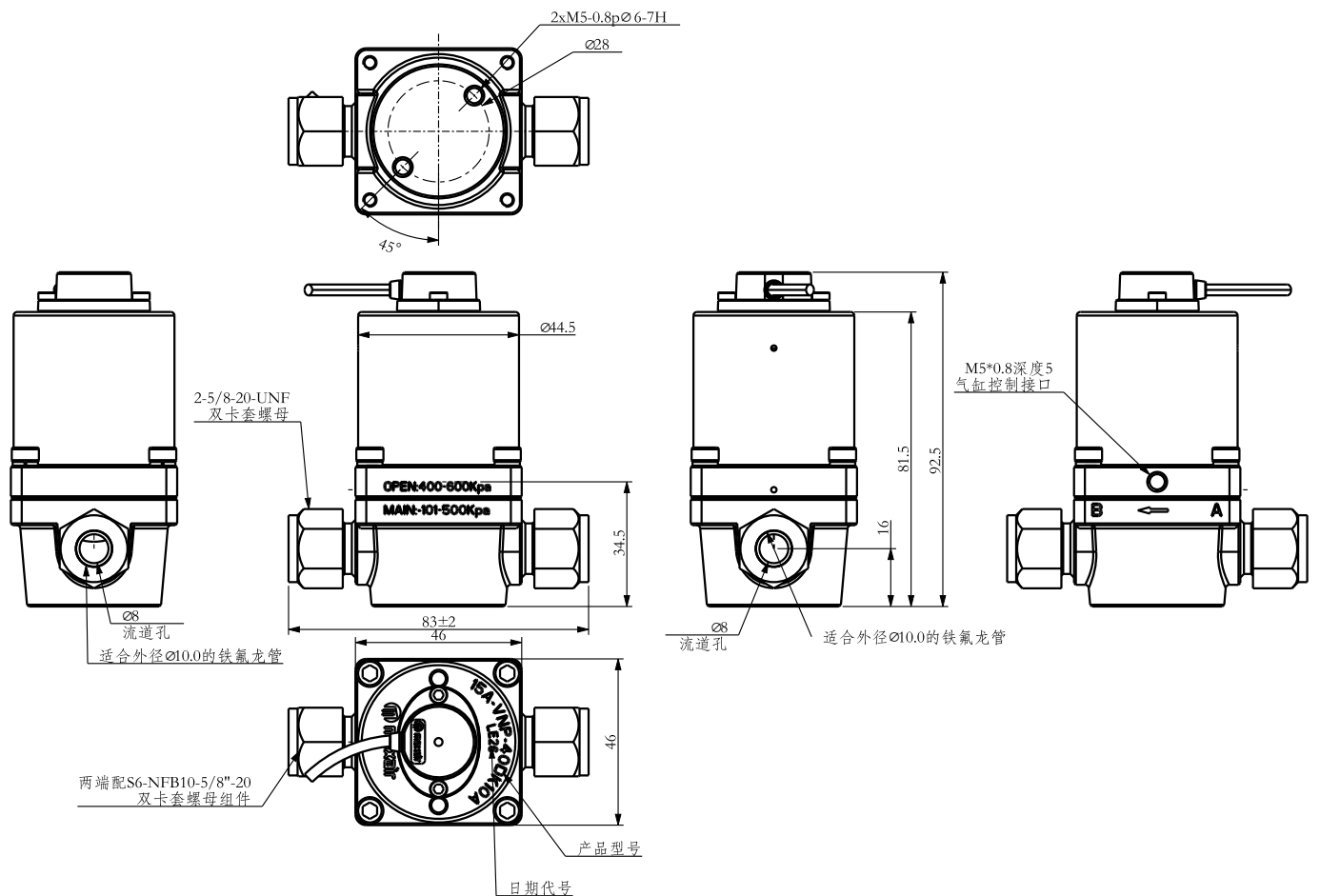

流道孔: Flow hole
 气缸控制接口: Cylinder control port
 产品型号: Product Model
 日期代号: Date Code
 双卡套螺母: Double ferrule nut
 适合外径XX的铁氟龙管: suitable for PTFE tube with outer diameter XX mm.
 位置传感器: Position sensor
 适合XX的插管: Suitable for XX outer diameter tube
 未装卡套螺母的长度: Tube end length without ferrule nut installed
 深度X: Depth X
 两端配双卡套螺母组件: Both ends fitted with double ferrule nut assemblies.
 阀体通径: Valve body bore diameter
 位置反馈传感器: Position Feedback sensor
 通径: Bore diameter
 配XXX双卡套螺母组件: Equipped with [XXX] double ferrule nut assembly
 含螺母、前卡、后卡: Including nut, front ferrule, and back ferrule

注液阀

VNP系列

外观尺寸图

► 15A-VNP-40DK10A(C)

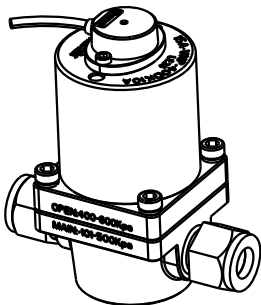
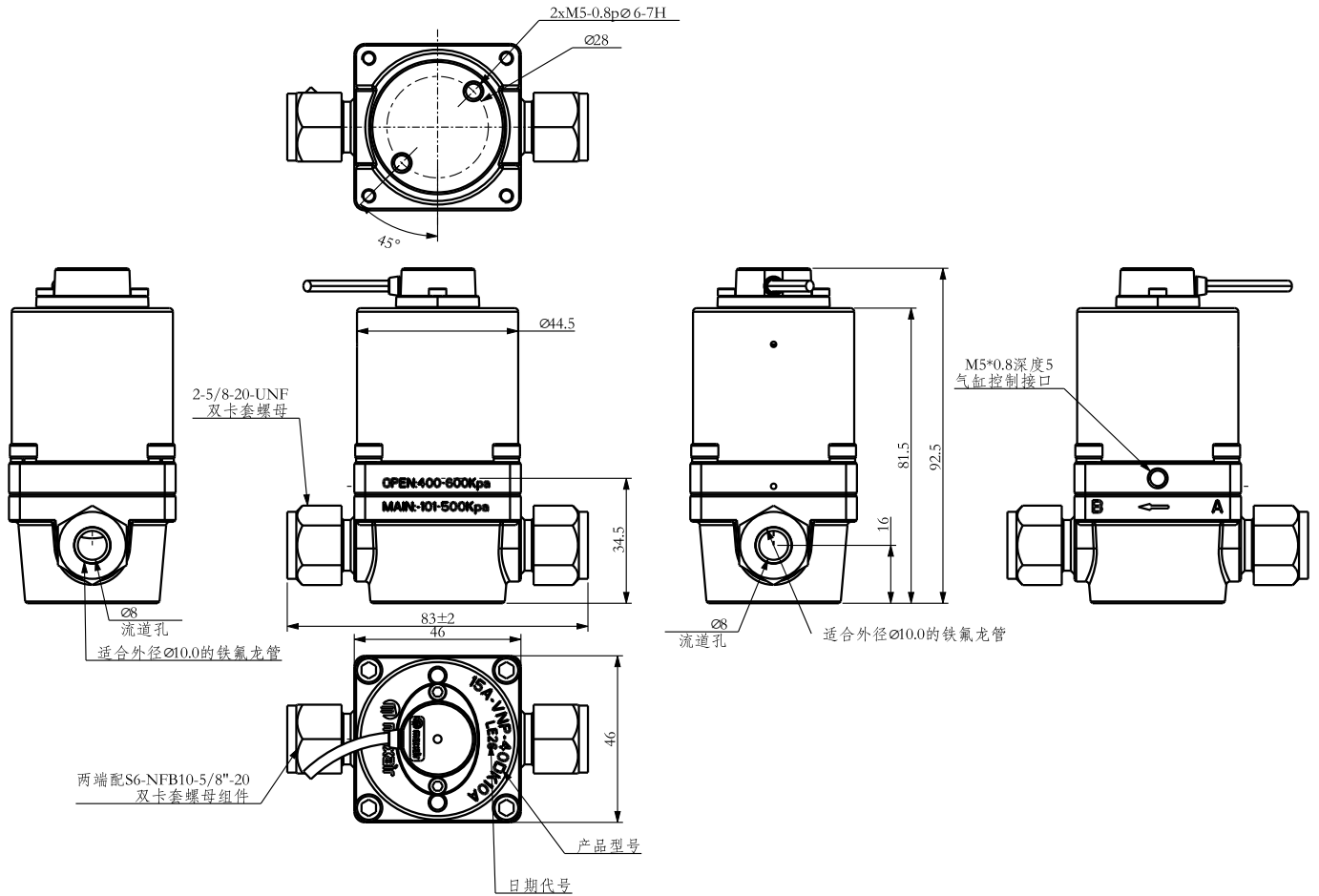

流道孔: Flow hole
 气缸控制接口: Cylinder control port
 产品型号: Product Model
 日期代号: Date Code
 双卡套螺母: Double ferrule nut
 适合外径XX的铁氟龙管: Suitable for PTFE tube with outer diameter XX mm.
 位置传感器: Position sensor
 适合XX的插管: Suitable for XX outer diameter tube
 未装卡套螺母的长度: Tube end length without ferrule nut installed
 深度X: Depth X
 两端配双卡套螺母组件: Both ends fitted with double ferrule nut assemblies.
 阀体直径: Valve body bore diameter
 位置反馈传感器: Position feedback sensor
 直径: Bore diameter
 配XXX双卡套螺母组件: Equipped with [XXX] double ferrule nut assembly
 含螺母、前卡、后卡: Including nut, front ferrule, and back ferrule

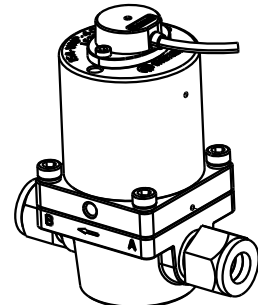

注液阀

VNP系列

外观尺寸图

▶ 15A-VNP-40DK12(B)

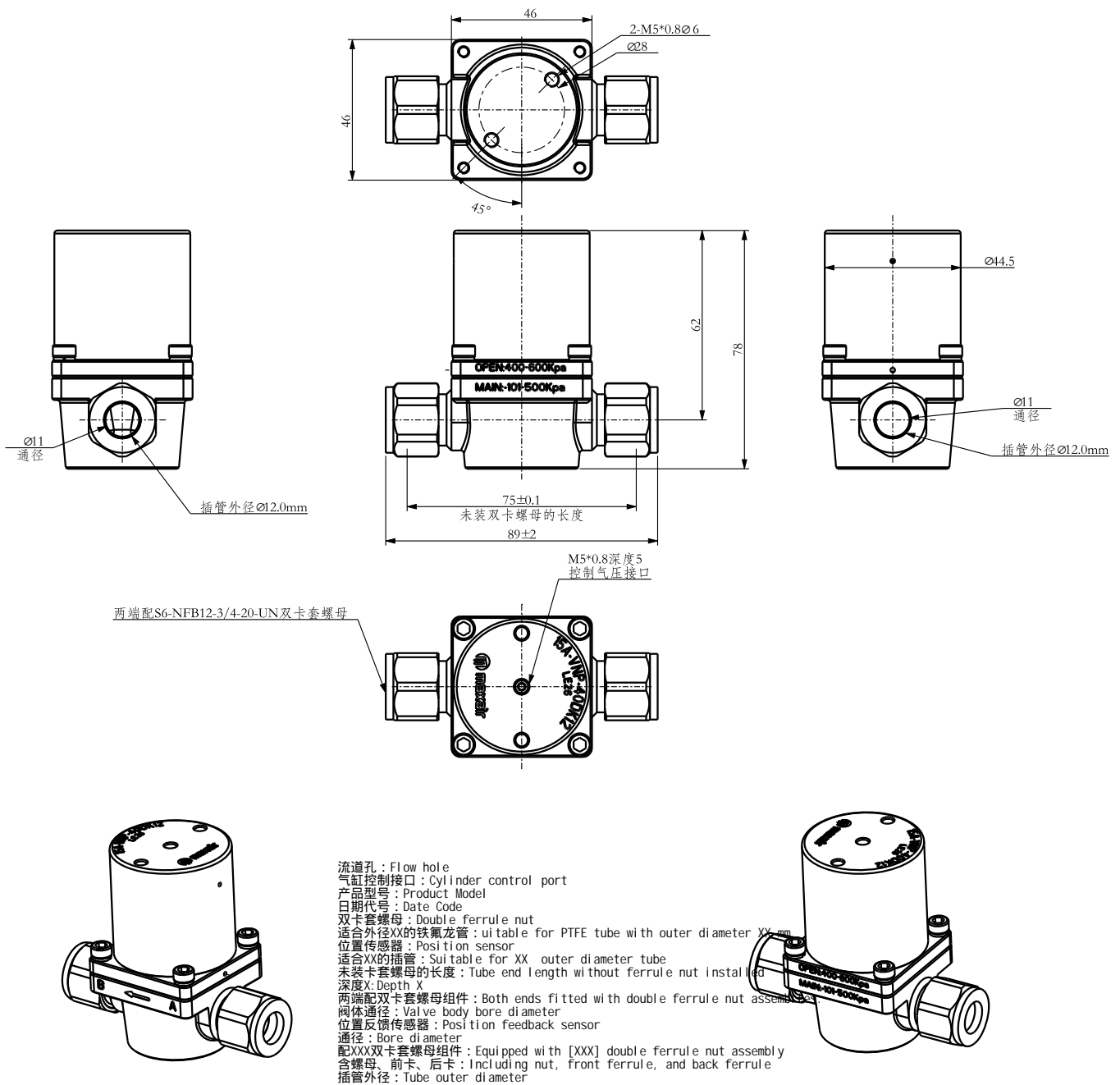

注液阀

VNP系列

外观尺寸图

► 15A-VNP-40DK12A(B)

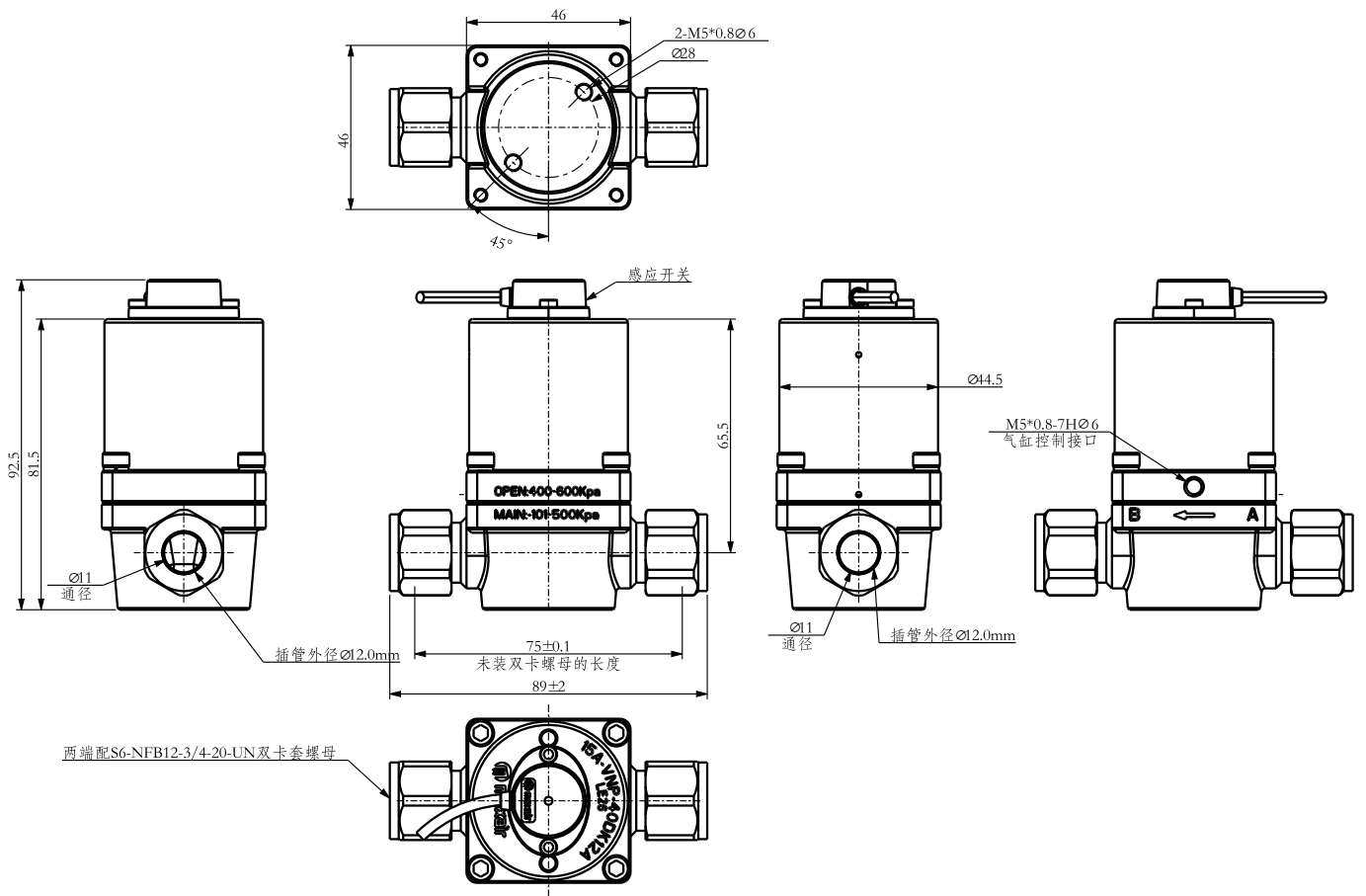

两端配S6-NFB12-3/4-20-UN双卡套螺母

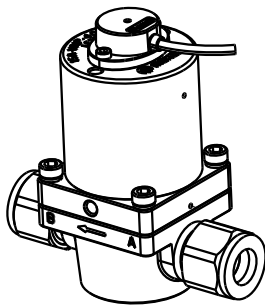

流道孔: Flow hole
 气缸控制接口: Cylinder control port
 产品型号: Product Model
 日期代号: Date Code
 双卡套螺母: Double ferrule nut
 适合外径XX的铁氟龙管: suitable for PTFE tube with outer diameter XX mm.
 位置传感器: Position sensor
 适合XX的插管: Suitable for XX outer diameter tube
 未装卡套螺母的长度: Tube end length without ferrule nut installed
 深度X: Depth X
 两端配双卡套螺母组件: Both ends fitted with double ferrule nut assemblies.
 阀体通径: Valve body bore diameter
 位置反馈传感器: Position feedback sensor
 通径: Bore diameter
 配XXX双卡套螺母组件: Equipped with [XXX] double ferrule nut assembly
 含螺母、前卡、后卡: Including nut, front ferrule, and back ferrule
 插管外径: Tube outer diameter

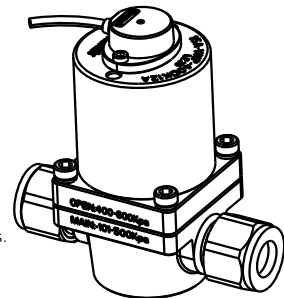

注液阀 VNP系列

外观尺寸图

▶ 15A-VNP-40DR02(B)

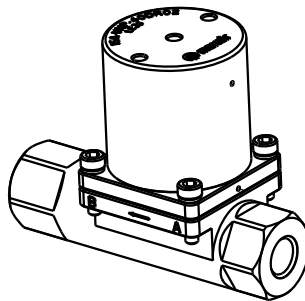
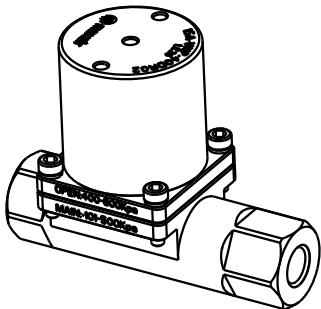
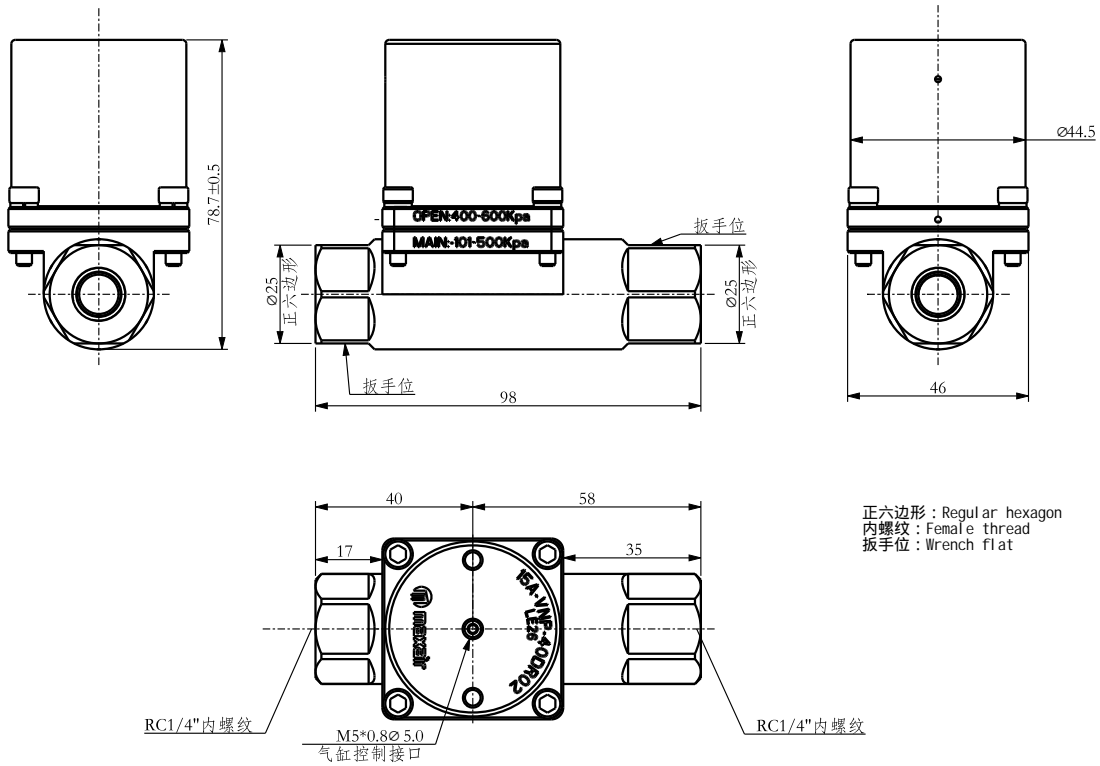

注液阀

VNP系列

外观尺寸图

► 15A-VNP-40DR02A(B)

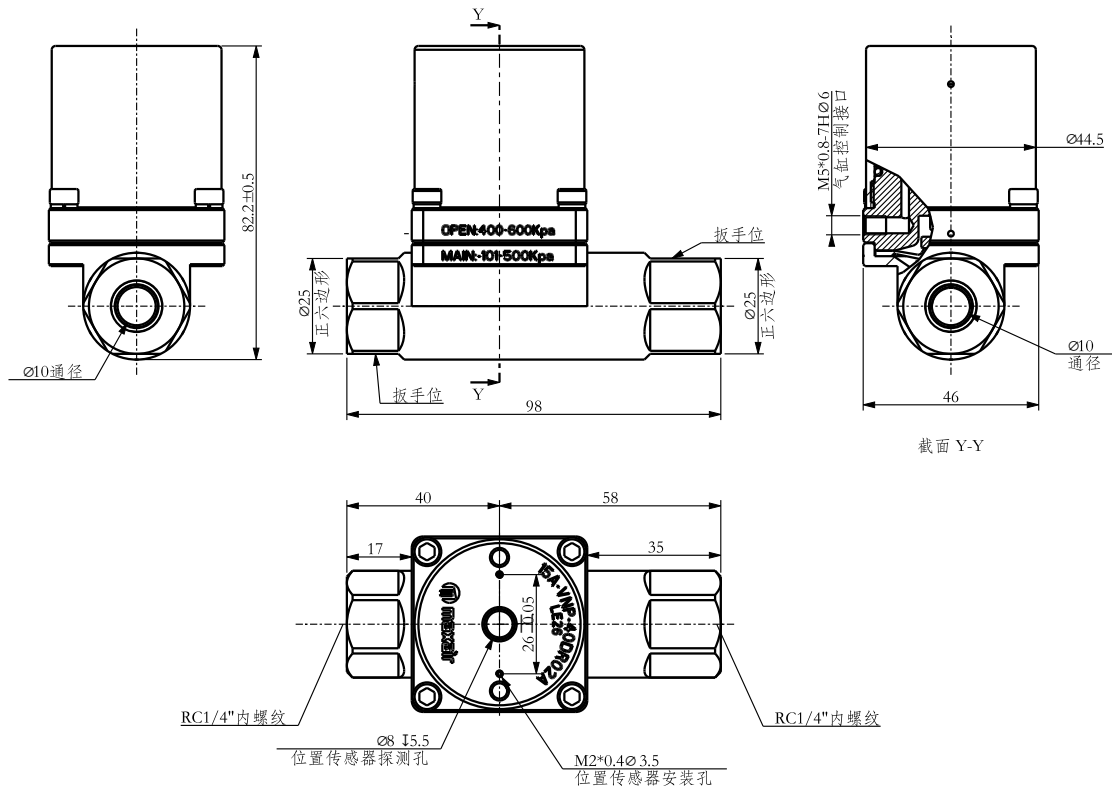

正六边形: Regular hexagon
 内螺纹: Female thread
 扳手位: Wrench flat
 位置传感器探测孔: Position sensor detection hole
 位置传感器安装孔: Position sensor mounting hole
 截面: Section

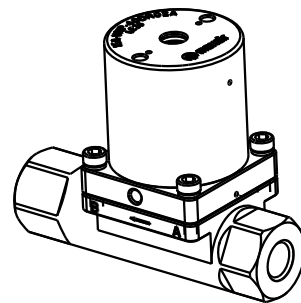
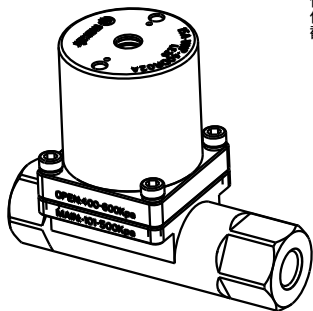

注液阀 VNP系列

外观尺寸图

► 15A-VNP-40DR03(B)

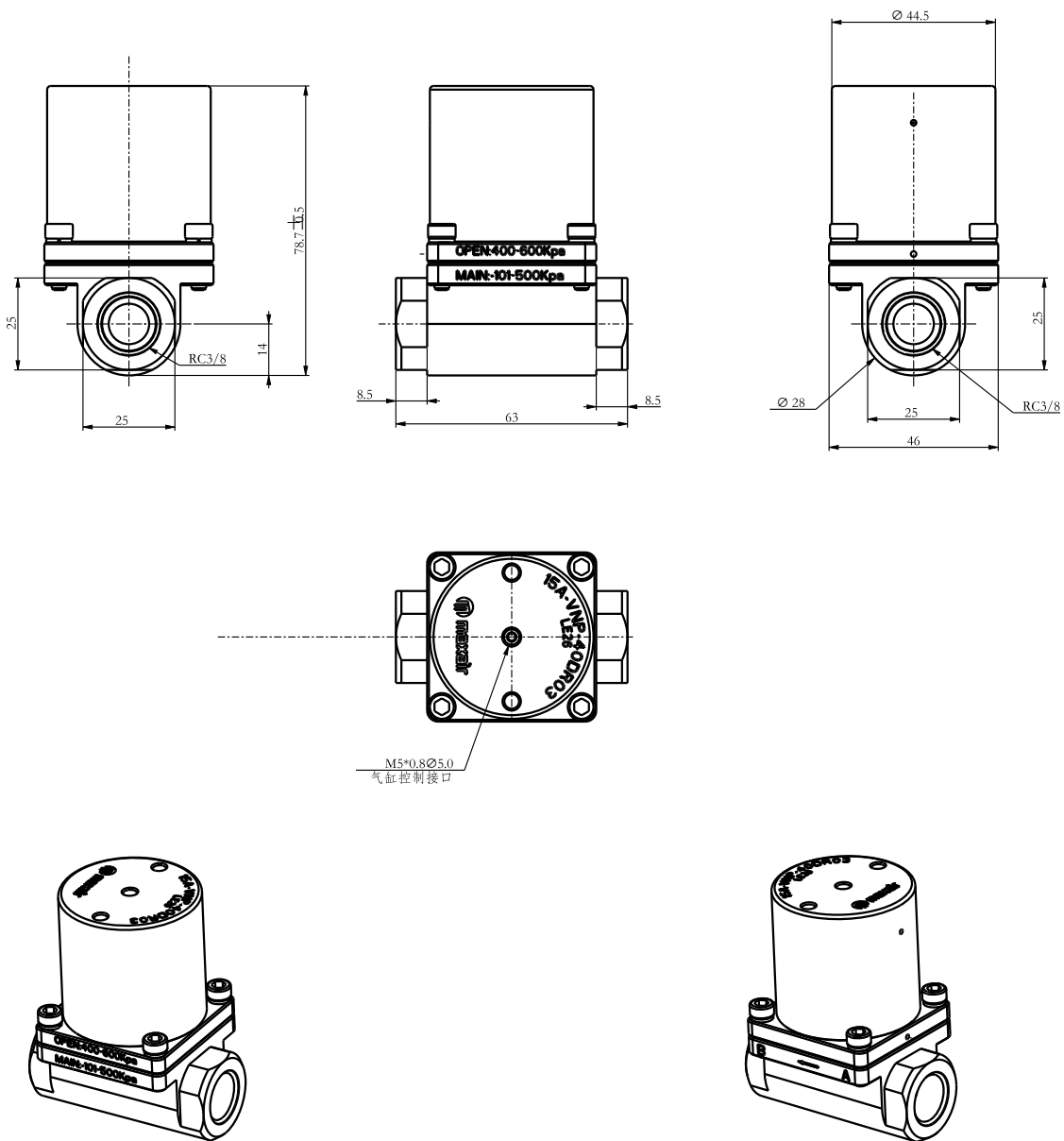

注液阀

VNP系列

外观尺寸图

► 15A-VNP-40DR04(B)

正六边形: Regular hexagon
 内螺纹: Female thread
 扳手位: Wrench flat
 位置传感器探测孔: Position sensor detection hole
 位置传感器安装孔: Position sensor mounting hole
 截面: Section

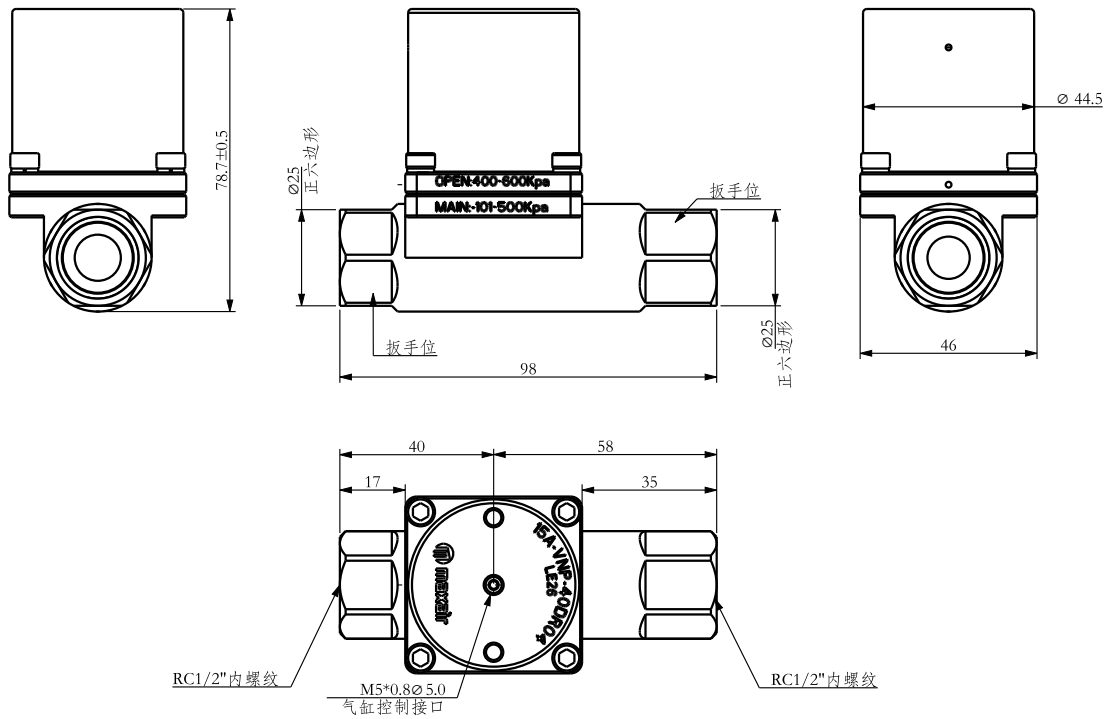

正六边形: Regular hexagon
 内螺纹: Female thread
 扳手位: Wrench flat
 位置传感器探测孔: Position sensor detection hole
 位置传感器安装孔: Position sensor mounting hole
 截面: Section

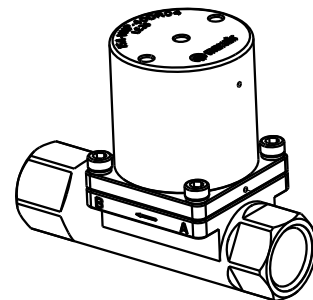
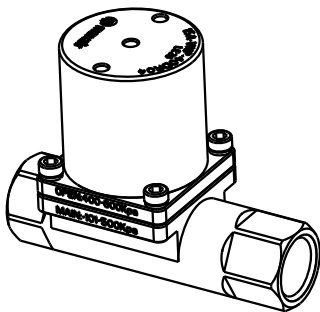

注液阀 VNP系列

外观尺寸图

▶ 15A-VNP-40DR04A(B)

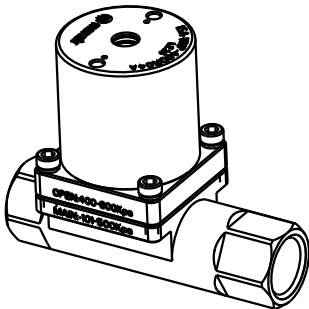
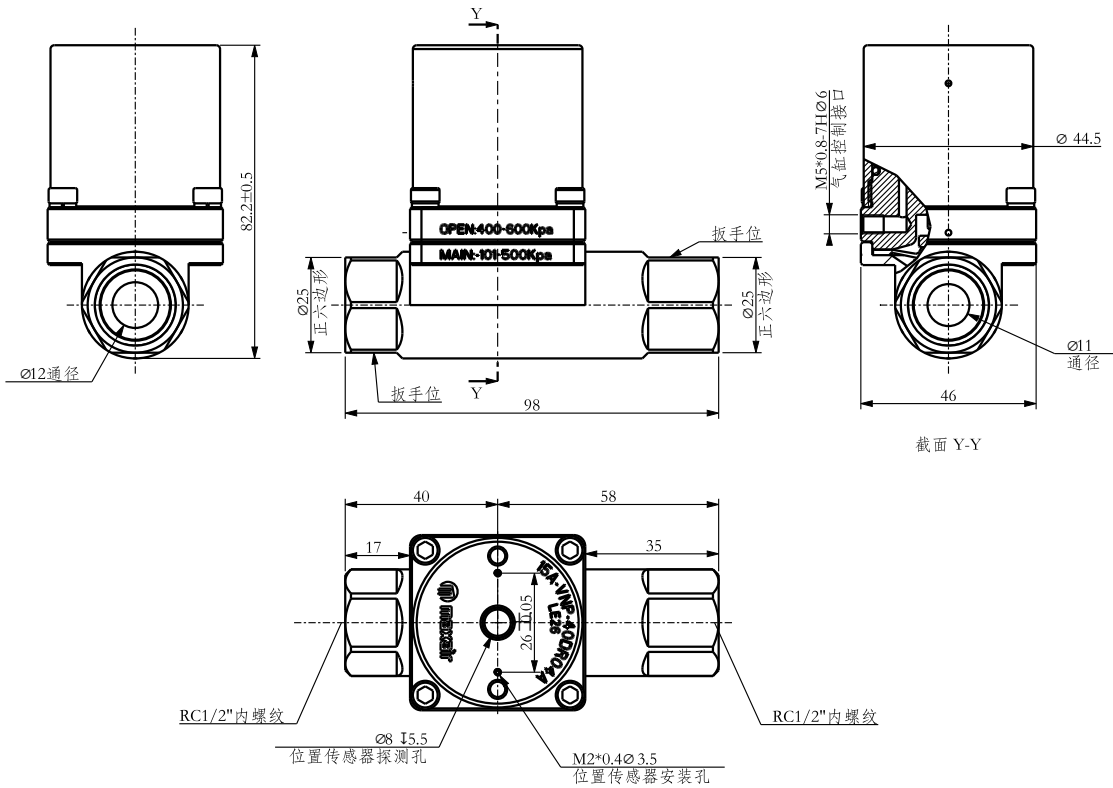

正六边形: Regular hexagon
 内螺纹: Female thread
 扳手位: Wrench flat
 位置传感器探测孔: Position sensor detection hole
 位置传感器安装孔: Position sensor mounting hole
 截面: Section

